

GIGACER<sup>®</sup>

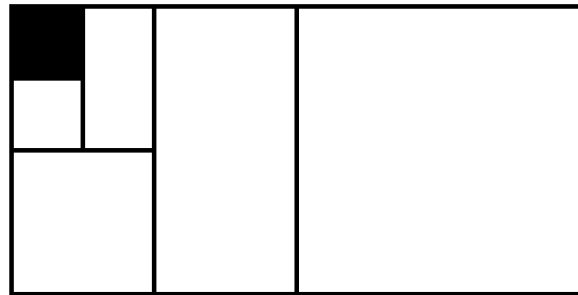

**G I G A C E R**<sup>®</sup>

General catalogue 2021

# INDEX

## / COLLECTIONS

### GIGACER®

Argilla	p. 6
Concept 1	p. 14
Concrete	p. 22
Déco	p. 30
Inclusioni	p. 34
Krea	p. 42
Light	p. 50
Made 2.0	p. 58
Quarry	p. 66

### Le Colours

Béton	p. 76
LCS	p. 80
Tokyo	p. 86
Molitor	p. 90
Pointillé	p. 94

## / SYSTEM - matching suggestion with our collections

### AVANTIME

Chromatic Vision	p. 104
------------------	--------

### PlayOne

Shapes - Mosaics - Brick Bar	p. 156
------------------------------	--------

## / TECHNICAL NOTES

Bordi e top   Edges and worktop	p. 182
Lavabi   Washbasins	p. 184
Piatti doccia   Shower trays	p. 185
Gigacer Service	p. 186
Pezzi speciali   Special trims	p. 188
Destinazioni d'uso   Intended use classification	p. 190
≠24 mm	p. 192
Posa e colla   Installation and adhesives	p. 194
Pulizia e manutenzione   Cleaning and maintenance	p. 196
Indice di stonizzazione   Shade variation index	p. 200
Calibri   Calibers	p. 201
Imballi   Packaging	p. 202
Caratteristiche tecniche   Technical specifications	p. 206
Certificazioni   Certifications	p. 208

Gigacer produce ceramica: grandi lastre in gres porcellanato tecnico per l'architettura. La ceramica attraversa la nostra storia, racchiudendo in sé dalle tracce più antiche dell'uomo fino alla miglior tecnologia industriale, che permette la produzione di un materiale sostenibile, ecocompatibile, resistentissimo, igienico e allineato alle tendenze del design contemporaneo. La ceramica è costituita da materiali naturali, è assolutamente inodore, non brucia e, in caso di incendio, non rilascia sostanze nocive. Il made in Italy in ceramica è sinonimo di stile e qualità, grazie al know-how sviluppato dalla manifattura, dalla raffinata tradizione artistica e anche grazie alle contaminazioni con gli altri settori dell'industria del design nazionale. Gigacer, nata a Faenza nel 2008, è figlia di questa terra e di queste competenze. Nasce sulla scorta di una tecnologia innovativa per la produzione di grandi lastre ceramiche e garantisce i migliori standard qualitativi del settore grazie alla competenza dei suoi addetti, cresciuti professionalmente dentro la cultura ceramica italiana. Il gres porcellanato Gigacer è batteriostatico, non permette cioè la proliferazione di batteri o virus sulla sua superficie, ed è notoriamente un materiale facilmente igienizzabile, grazie alla sua durezza e compattezza. Il sito produttivo a Faenza è stato costruito rispettando le migliori prassi europee e regionali, utilizzando tecnologie d'avanguardia e facendo del rispetto dell'ambiente un tratto distintivo e imprescindibile dell'intero progetto. Osservando lo spessore delle lastre 12 mm multilayer si può notare che la base, composta di gres porcellanato ottenuto anche con l'aggiunta del riciclo degli sfridi produttivi, viene ricoperta da uno strato di materiale nobile, composto da gres porcellanato colorato in massa, argille, grani, che vengono depositati sulla superficie prima della pressatura. Questo metodo di lavorazione, oltre a regalare al prodotto un aspetto visibilmente e concretamente materico, ottimizza l'uso dei materiali. Elemento cardine dello sviluppo dell'azienda, come vedrete sfogliando le pagine successive, è lo stile originale: contemporaneo, minimalista, raffinato. Gigacer mantiene fin dall'inizio uno stile univoco: la matericità delle superfici e i loro colori naturalmente eleganti vengono studiati per essere uno sfondo neutro, curato e sofisticato per l'abitare.

Gigacer produces ceramic: large technical porcelain stoneware slabs for architecture. Ceramic runs through our history, encompassing from the most ancient traces of mankind to the best industrial technology, which allows the production of a sustainable, environmentally friendly, highly resistant, hygienic material and aligned material with contemporary design trends. The ceramic is made with the use natural elements, it is absolutely odorless, it does not burn and, in the event of a fire, it does not release harmful substances. Made in Italy in ceramics is synonymous with style and quality, thanks to the know-how developed by manufacturing, the refined artistic tradition and also thanks to the contamination with other sectors of the national design industry. Gigacer, born in Faenza in 2008, is the daughter of this land and these skills. It was born on the basis of an innovative technology for the production of large ceramic slabs and guarantees the best quality standards in the sector thanks to the expertise of its employees, who have grown professionally within the Italian ceramic culture. Gigacer porcelain stoneware is bacteriostatic, which means that it does not allow the proliferation of bacteria or viruses on its surface, and is notoriously an easily sanitized material, thanks to its hardness and compactness. The production site in Faenza was built respecting the best European and Regional practices, using cutting-edge technologies and making respect for the environment a distinctive and essential feature of the entire project. Close observation of the slabs 12 mm multilayer shows that the base - made up of porcelain stoneware obtained partially by the addition of recycled offcuts of the same material - is coated with a layer of noble material made up of porcelain stoneware coloured en masse and clays and grains which are deposited onto the surface prior to pressing. In addition to producing a visibly and concretely material product, this working method optimises material use. The cornerstone of the company's development, as you can see by browsing the following pages, is the original style: contemporary, minimalist and refined. Gigacer maintains a unique style right from the start: the materiality of the surfaces and their naturally elegant colors are designed to be a neutral, refined and sophisticated background for living.

# / GIGACER COLLECTIONS

Argilla  
Concept 1  
Concrete  
Déco  
Inclusioni  
Krea  
Light  
Made 2.0  
Quarry



# Argilla

Argilla riscopre le espressioni più naturali delle terre faentine, le argille, creando una gamma cromatica dalla tonalità pastello, in cui la materia diventa protagonista. Le due superfici della collezione, che interpretano il medesimo colore, sottolineano la plasticità della nostra materia prima: quasi cerosa e morbidissima la superficie Quartz, materica e pastosa Material.

Argilla rediscovers the most natural expressions of the Faentinian lands, the clays, creating a chromatic range with a pastel shade, where the material becomes the main subject. The two surfaces of the collection, which interpret the same color, underline the plasticity of our raw material: the Quartz surface, material and pasty Material, is almost waxy and very soft.

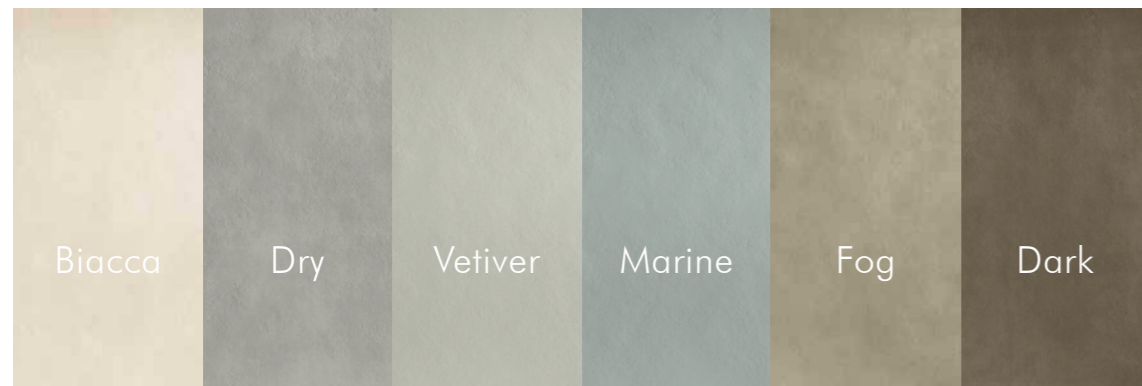



# Argilla



Le 6 tonalità di colore sono fra loro affini, interpretate da due diverse superfici:  
**Quartz e Material ideali per pavimenti e rivestimenti.**  
 These 6 colours shades are available on two different surfaces:  
 Quartz and Material for both floor and wall applications.

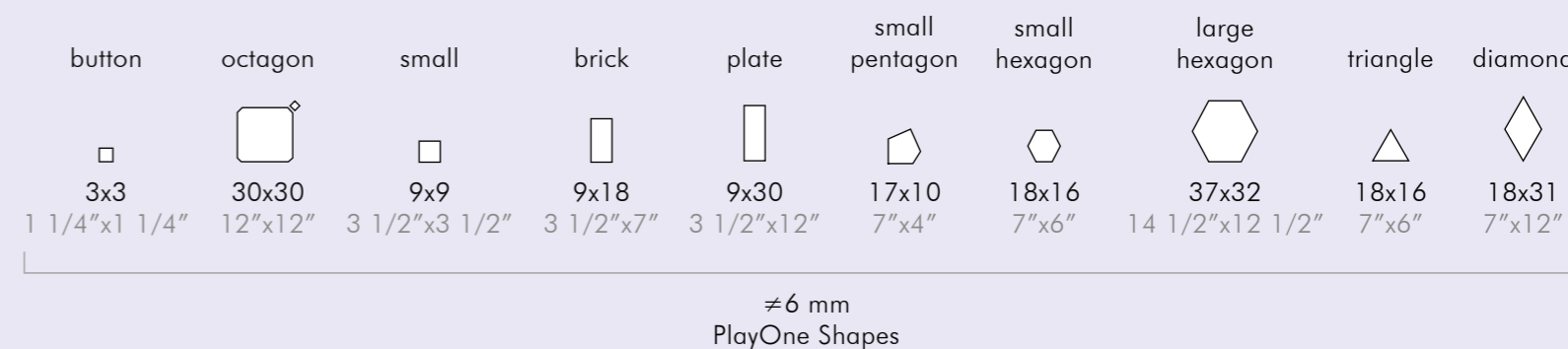
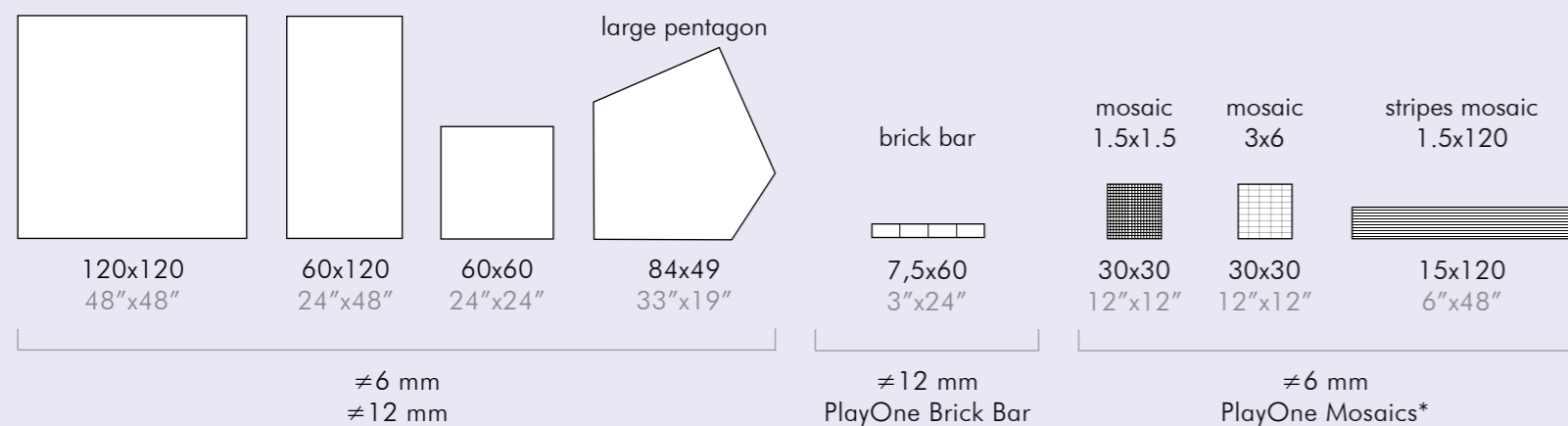
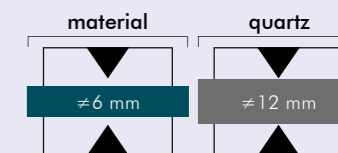

\*Mosaici forniti su rete  
 Mosaics are mesh-mounted

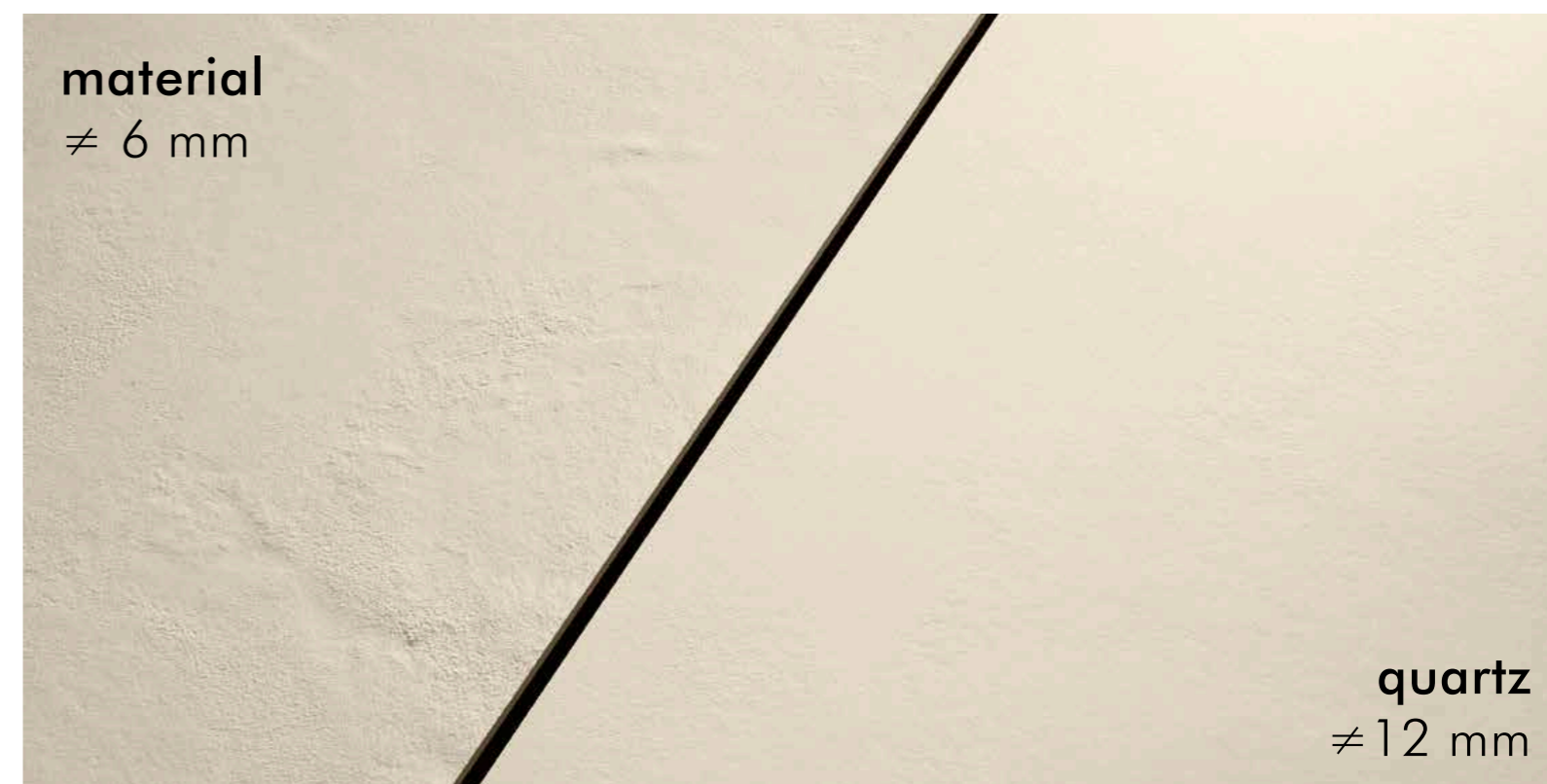





**Parete | Wall**  
Marine Argilla Material  
120x120 cm · 48"x48" ±6 mm

**Pavimento | Floor**  
Marine Argilla Quartz  
120x120 cm · 48"x48" ±12 mm



**Parete | Wall**  
Vetiver Argilla Material  
60x120 cm · 24"x48" ±6 mm

Vetiver Argilla Material  
Stripes Mosaic 1.5x120 - 15x120 cm · 6"x48" ±6 mm

Curtain Light 250  
120x250 cm · 48"x100" ±6 mm

**Pavimento | Floor**  
Vetiver Argilla Material  
120x120 cm · 48"x48" ±6 mm

Vetiver Argilla Material  
Stripes Mosaic 1.5x120 - 15x120 cm · 6"x48" ±6 mm





**Piano dei tavolini | Counter top coffee**  
All colours Argilla Material  $\approx 6$  mm  
Gigacer Service

**Pavimento | Floor**  
Fog Argilla Material  
120x120 cm · 48"x48"  $\approx 6$  mm



**Parete | Wall**  
Dark Argilla Material  
Mosaic 3x6 - 30x30 cm · 12"x12"  $\approx 6$  mm

**Piano dei tavolini | Counter top coffee**  
All colours Argilla Material  $\approx 6$  mm  
Gigacer Service

**Pavimento | Floor**  
Fog Argilla Material  
120x120 cm · 48"x48"  $\approx 6$  mm



# Concept 1

Concept 1 è concepire lo spazio con unità di forma e stile, con soluzioni tecniche che conservano continuità estetica attraverso gli ambienti e la loro molteplicità di utilizzi, in interno, in esterno, a parete e nell'arredo, in breve: tutto in uno.

Un'unica gamma in ceramica pensata per ogni tipo di applicazione, con una varietà di colori e superfici combinabili sempre in modo esclusivo e personale. Un gres porcellanato resistente, eclettico, dai toni naturali ed omogenei, con 5 colori di fondo, 5 diverse superfici e 3 spessori.

Concept 1 is to conceive space with unity of form and style, using technical solutions that maintain aesthetic continuity through the environments and their multiplicity of uses, indoors, outdoors, on walls and furniture, in short: all in one.

A unique ceramic range designed for every type of application, with a variety of colours and surfaces that can always be combined in an exclusive and personal way.

A resistant, eclectic porcelain stoneware in natural and homogeneous shades, with 5 colours, 5 different surfaces and 3 thicknesses.

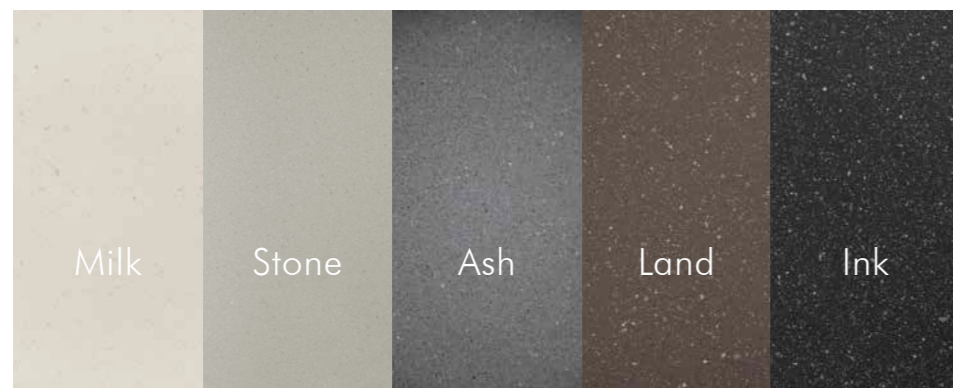



# Concept 1



\* Disponibile solo nella superficie Bocciardato R10 e R11 multilayer, specificare nell'ordine.  
Available only in multilayer Bocciardato R10 and R11 surface, to be specified in the order.

\*\* Disponibile tutta massa non rettificato mat / levigato. Available full body not rectified mat / levigato.

◆ Gli articoli con il marchio Gigacer Service saranno prodotti solo su specifica richiesta e quotati ove necessario (pag. 186).  
The products with the Gigacer Service label will be manufactured only upon specific request and they will be quoted where necessary (page 186).

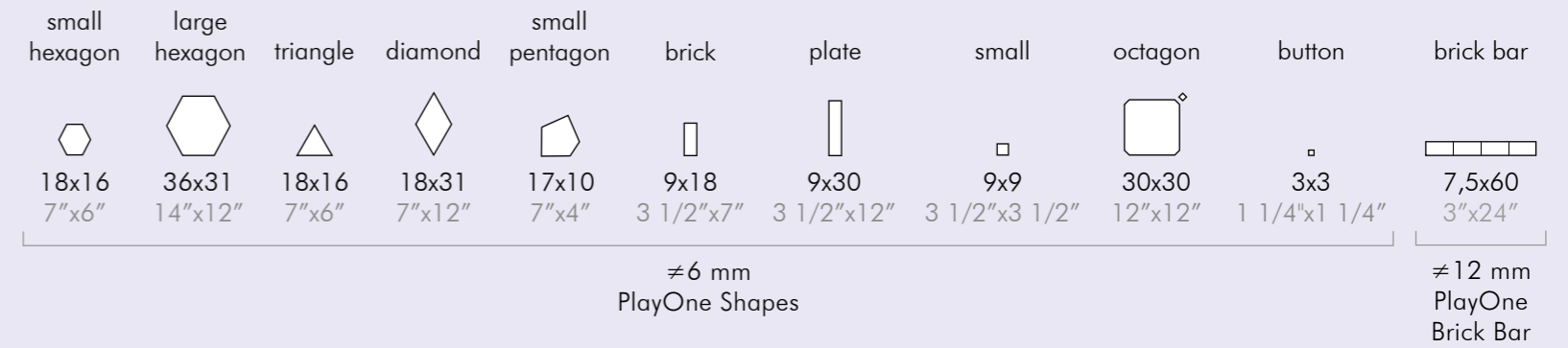
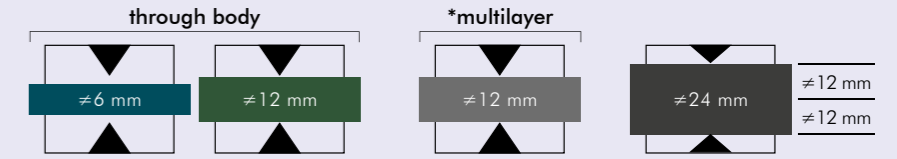
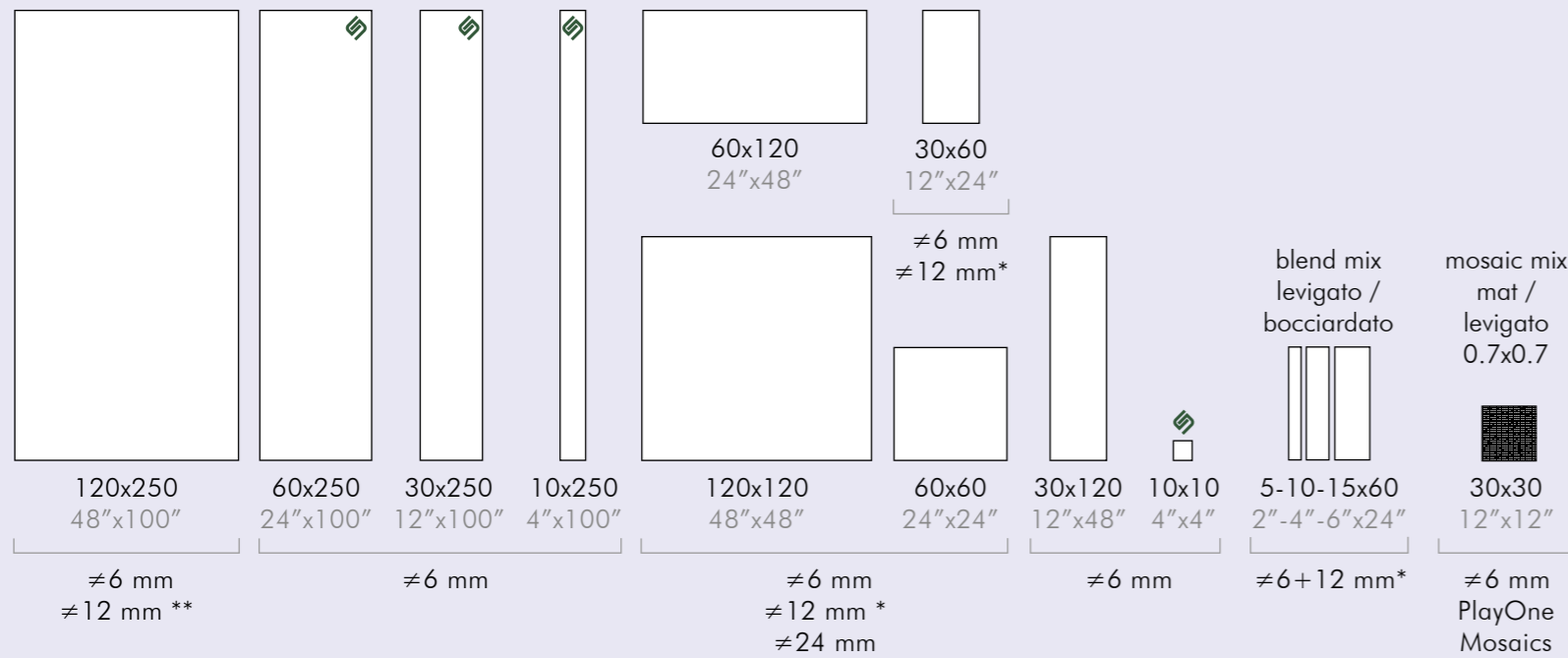

## Superfici Surfaces

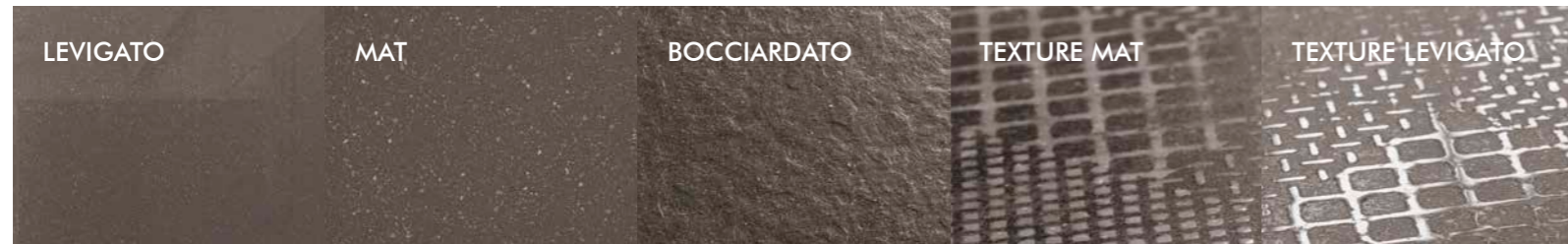

## Colori Colours

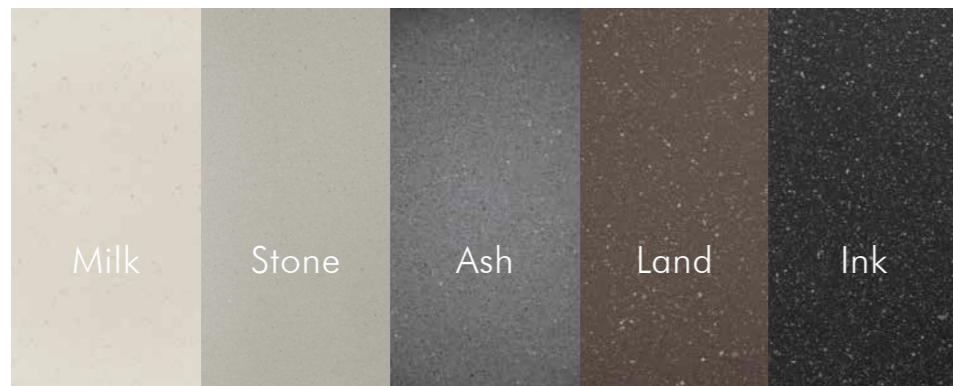

Platinum, Red, Turquoise e Flame Texture Mat sono disponibili solo su base colore Ink.  
Platinum, Red, Turquoise and Flame Texture Mat are available on Ink colour basis only.

Mosaici forniti su rete  
Mosaics are mesh-mounted

COLORE COLOUR	SUPERFICIE SURFACE	SPESSORE THICKNESS	120x250 48"x100" unrect.	120x250 48"x100"	60x250 24"x100"	30x250 12"x100"	10x250 4"x100"	10x10 4"x4"	120x120 48"x48"	60x120 24"x48"	60x60 24"x24"	30x120 12"x48"	30x60 12"x24"	PLAYONE SHAPES	PLAYONE MOSAICS	PLAYONE BRICK BAR
Milk Stone Ash Land Ink	Mat Levigato	# 6	-	•	◆	◆	◆	◆	•	•	•	•	•	•	•	-
	Texture Mat Texture Levigato	# 6	-	•	◆	◆	◆	◆	•	•	•	•	•	•	-	-
Milk Stone Ash Land Ink	Mat Levigato	# 12	•	-	-	-	-	-	-	-	-	-	-	-	-	•
Milk Stone Ash Land Ink	Bocciardato R10 (Also in Bocciardato R11 anti-slip. Specify in the order).	# 12	-	-	-	-	-	-	•	•	•	-	•	-	-	•
Ink Platinum Ink Red Ink Turquoise Ink Flame	Texture Mat	# 6	-	•	◆	◆	◆	◆	•	•	•	-	•	◆	◆	-
Milk Stone Ash Land Ink	Mat Bocciardato R10 (Also in Bocciardato R11 anti-slip. Specify in the order).	# 24	-	-	-	-	-	-	◆	◆	◆	-	-	-	-	-

- Disponibile Available
- Non disponibile Not available





**Rivestimento | Wall / Pavimento | Floor**

Milk Texture Levigato Concept 1  
120x250 cm · 48"x100" / 20x250 cm · 8"x100" ⚡ Gigacer Service ≠6 mm

Milk Mat Concept 1  
60x250 cm · 24"x100" Gigacer Service / 20x250 cm · 8"x100" ⚡ Gigacer Service ≠6 mm

Milk Levigato Concept 1  
60x250 cm · 24"x100" Gigacer Service / 40x250 cm · 16"x100" ⚡ Gigacer Service ≠6 mm

**Lavabo | Wash basin "Middle"**

Milk Mat Concept 1  
50x119 cm · 19 1/2"x48" ≠6 mm



**Parete | Wall**

(Indoor) Stone Texture Levigato Concept 1  
120x250 cm · 48"x100" ≠6 mm

(Outdoor) Stone Blend Levigato/Bocciardato Concept 1  
5/10/15x60 cm · 2"/4"/6"x24" ≠6 mm / ≠12 mm

**Pavimento | Floor**

Stone Bocciardato R11 Concept 1  
120x120 cm · 48"x48" ≠12 mm





**Parete | Wall**  
Ink Texture Levigato Concept 1  
120x250 cm · 48"x100" ≈6 mm

Ink Mat Concept 1  
60x250 cm · 24"x100" ≈6 mm Gigacer Service

Ink Turquoise Texture Mat Concept 1  
60x250 cm · 24"x100" ≈6 mm Gigacer Service

**Pavimento | Floor**  
Ink Bocciardato R11 Concept 1  
120x120 cm · 48"x48" ≈12 mm



**Ante cucina | Kitchen cabinets / Piano cucina | Kitchen Worktop**  
Land Mat Concept 1 ≈12 mm  
Gigacer Service



# Concrete

Concrete, in sinergia con Made 2.0 (pag. 58), è un flessibile sistema ceramico al servizio degli spazi abitativi. È la paletta di combinazione colori/superfici più completa nelle tinte neutre e naturali: tredici colori e quattro diverse superfici che si adattano alle diverse esigenze dell'abitare. Lo stesso colore può essere utilizzato dall'interno all'esterno, nei pavimenti e nei rivestimenti e per la realizzazione di piani cucina e mobili da bagno mantenendo una forte coerenza cromatica. Tutta la paletta colori Concrete corrisponde ai colori Made 2.0; il colore White equivale al Made 2.0 White Sand.

Concrete, in synergy with Made 2.0 (page 58), is a flexible ceramic system at the service of living spaces. It is the most complete color / surface combination palette in neutral and natural shades: thirteen colors and four different surfaces that adapt to the different needs of living. The same color can be used from inside to outside, in floors and walls and for the creation of kitchen tops and bathroom furniture while maintaining a strong color consistency. The whole Concrete color palette corresponds to the colors Made 2.0; the White color matches the Made 2.0 White Sand.

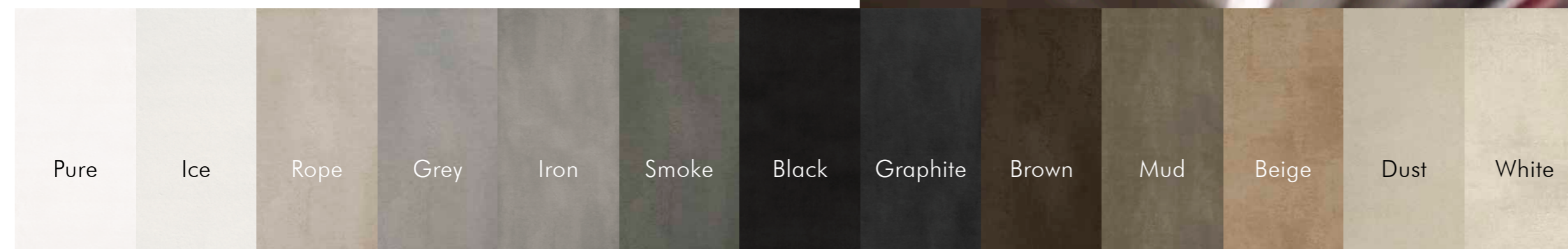



# Concrete



**\*I colori PURE e BLACK sono disponibili solo tutta massa ≠6mm nei formati:**  
 The colours PURE and BLACK are available in through body ≠6mm, only in the following sizes:  
 120x250, 60x250, 120x120, 60x120, 60x60, 30x60, Mosaic 30x30, Action Mosaic, Stripes Mosaic, Wall Mosaic.

**\*\*Disponibile il formato 120x250 rett./non rett. tutta massa nei colori:** Available size 120x250 rect/unrect through body in colours:  
 Rope / Grey / Graphite / Mud / White

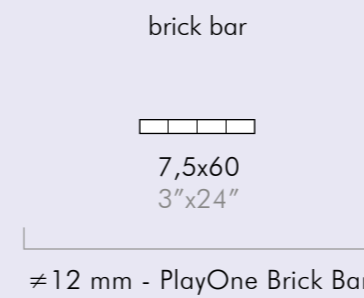
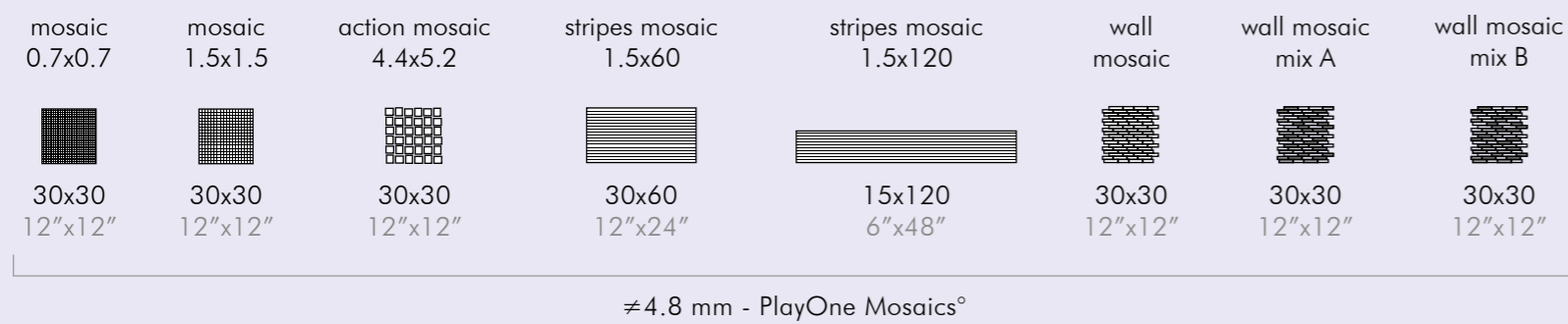
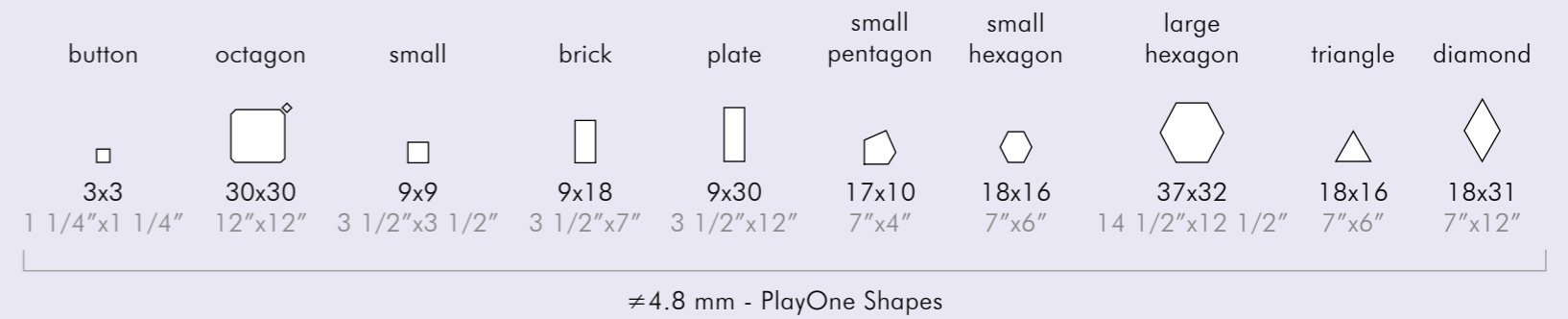
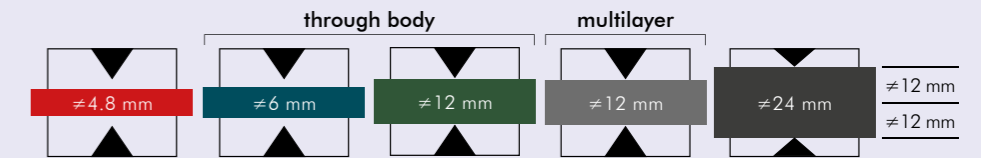
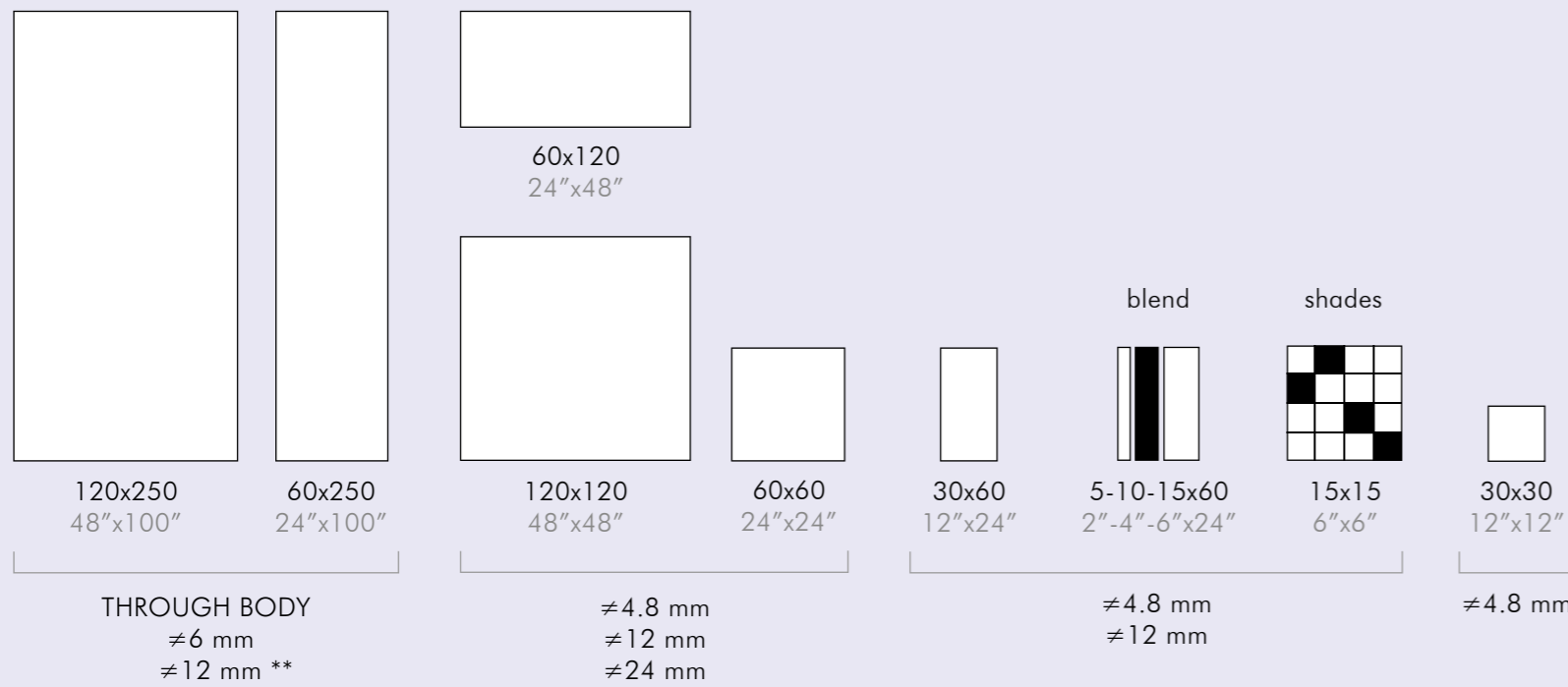

°Mosaici forniti su rete  
 Mosaics are mesh-mounted

**WALL MOSAIC MIX A**  
 Solo nei colori: only in the colours:  
 Brown / Beige / White

**WALL MOSAIC MIX B**  
 Solo nei colori: only in the colours:  
 Grey / Smoke / Graphite / White

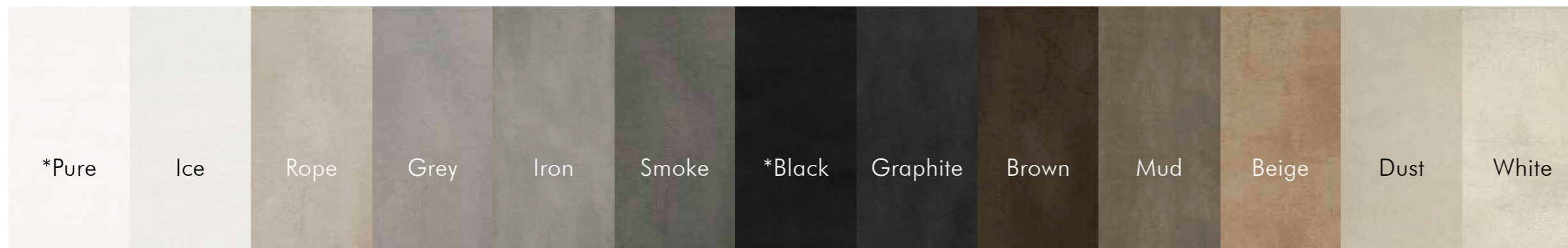





Pavimento | Floor  
Ice Concrete  
120x120 cm · 48"x48" ±12 mm

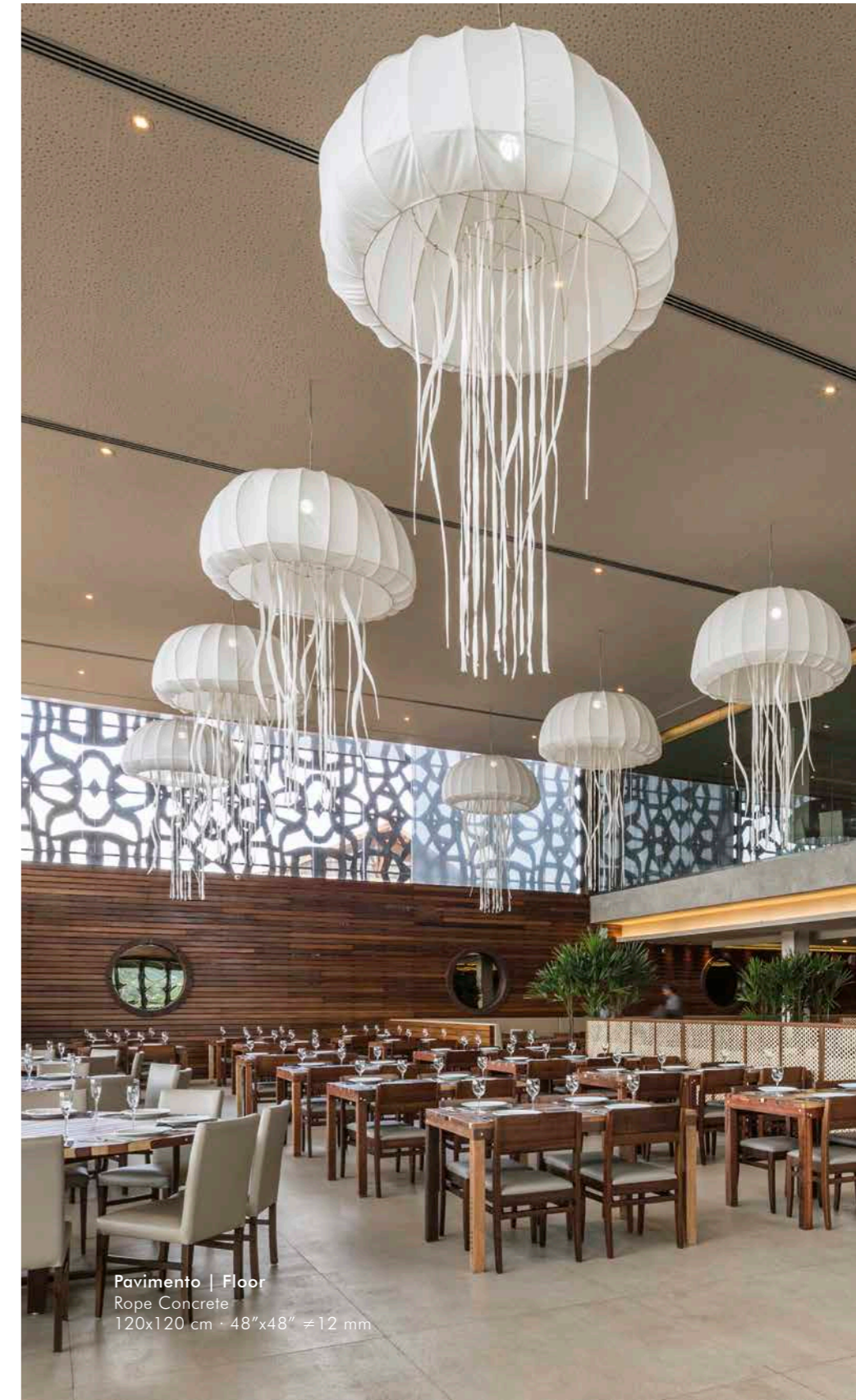

Pavimento | Floor  
Rope Concrete  
120x120 cm · 48"x48" ±12 mm





**Pavimento | Floor**  
Beige Concrete  
120x120 cm · 48"x48" ≈12 mm

**Top cucina | Kitchen worktop**  
Beige Concrete  
Gigacer Service

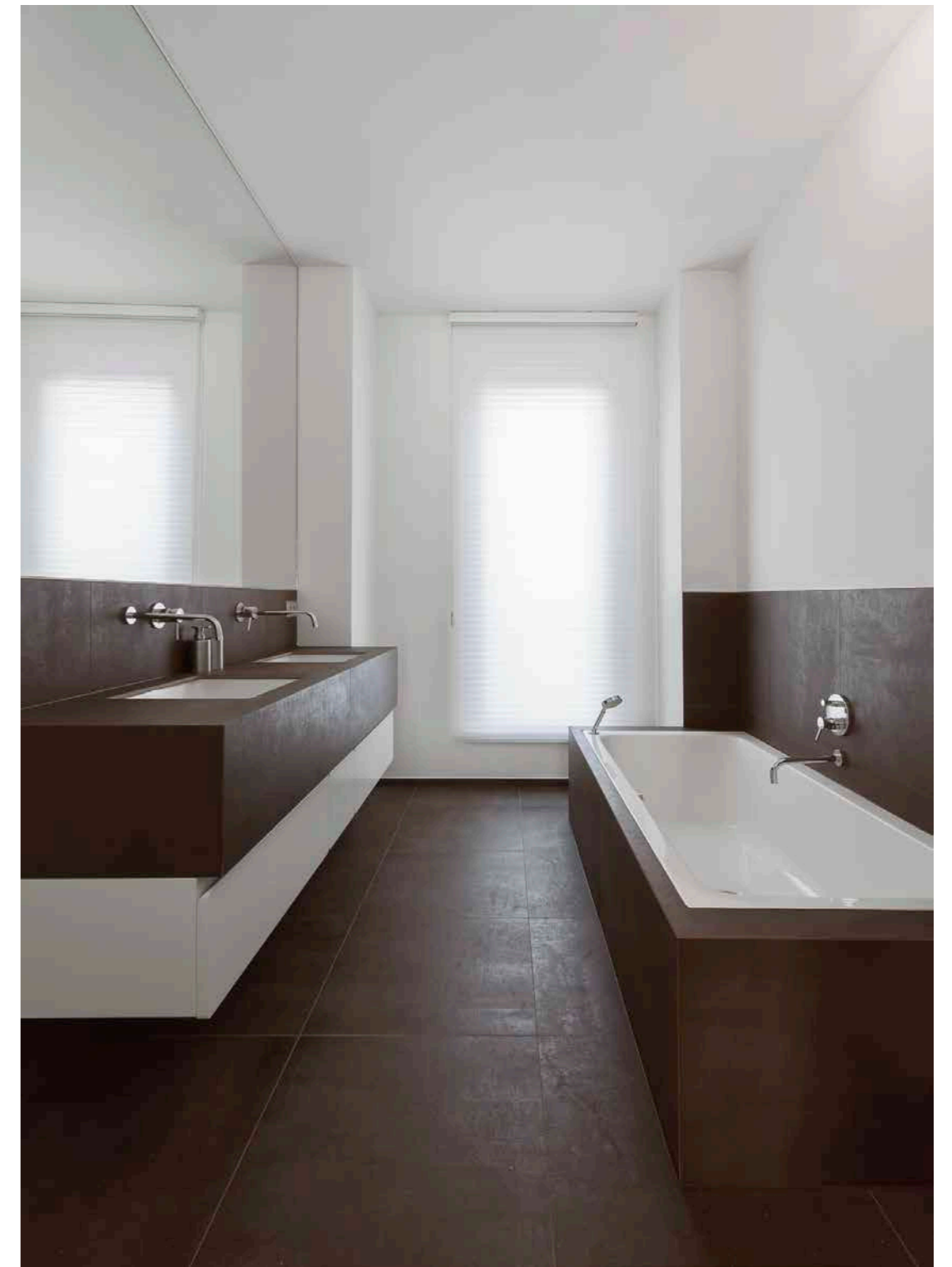

**Parete | Wall**  
Brown Concrete  
60x120 cm · 24"x48" ≈4.8 mm

**Pavimento | Floor**  
Brown Concrete  
60x60 cm · 24"x24" ≈12 mm

**Lavabo | Washbasin / Vasca | Bathtub**  
Brown Concrete  
Gigacer Service



# Déco

Déco si affida alle linee curve e ai dettagli floreali di un paesaggio immaginario, lasciando prevalere l'aspetto vetroso e traslucido ad effetto "ceramico". Si articola in tre gruppi cromatici, definiti in base a tre paesaggi, ognuno ispirato ai toni che lo connotano: Arctic, Mountain e Tropic. Viene presentata inoltre una lastra monocromatica dal fondo bianco neutro, tonalità inclusa in tutte le tre lastre colorate, che può essere utilizzata in abbinamento a tutta la collezione.

Déco relies on the curved lines and floral details of an imaginary landscape, allowing the glass-like and translucent "ceramic" effect prevail. Déco is divided into three colour groups, defined according to three landscapes, each inspired by the tones that characterize it: Arctic, Mountain and Tropic. A monochromatic slab with a neutral white background is presented too, a shade included in all three coloured options, which can be used in combination with the entire collection.





# Déco

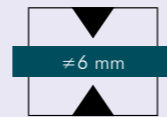
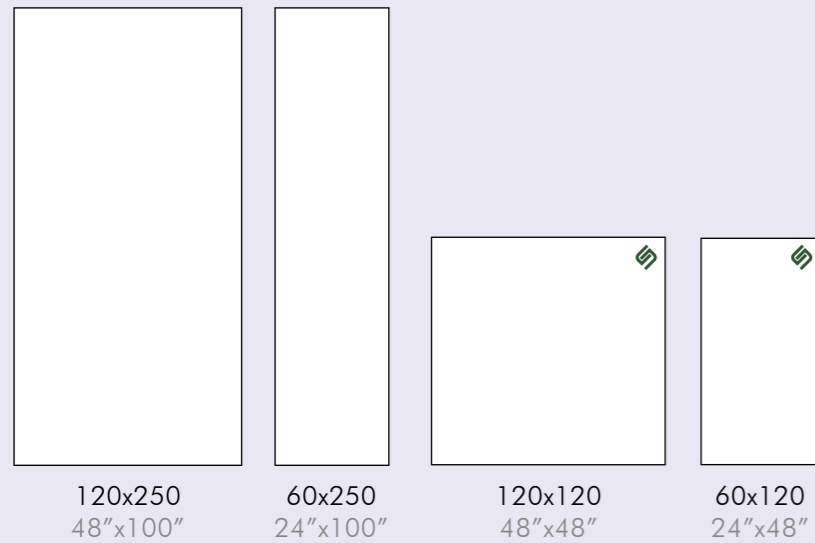

≈6 mm

**Si consiglia di tagliare questa collezione a disco.**  
We recommend to cut this collection using the wet saw.



A

B



Basic White

Arctic

Mountain

Tropic

**Grafiche continue** Continuous graphics

**Le lastre 120x250 cm vengono prodotte in due soggetti per ogni colore e per poter creare una posa continua (alternando i soggetti A/B/A/B...).**

The 120x250 slabs are manufactured in 2 subjects for each colour to create a continuous scheme (alternation A/B/A/B ...).



Basic White

Arctic

Mountain

Tropic

**❖ Gli articoli con il marchio Gigacer Service saranno prodotti solo su specifica richiesta e quotati ove necessario (pag. 186).**

The products with the Gigacer Service label will be manufactured only upon specific request and they will be quoted where necessary (page 186).



**Parete | Wall**  
Mountain Déco  
❖ Gigacer Service ≈6 mm

Black / Pure Concrete  
120x250 cm · 48" x 100" ≈6 mm

**Pavimento | Floor**  
Black / Pure Concrete  
120x120 cm · 48" x 48" ≈6 mm



# Inclusioni

Ispirata dalla forza paziente della natura, Inclusioni unisce la poesia dei colori e l'espressività delle forme aprendo la strada ad infinite possibilità creative. Le sue superfici sono autenticamente materiche e raffinate: scaglie in gres porcellanato prodotte sotto il sapiente controllo dei tecnici del nostro laboratorio vengono deposte sulla superficie e inglobate; il risultato è un effetto tangibile e tridimensionale. Cinque i colori degli ambienti: Bianco Perla, Ecrù, Tabacco, Cenere e Vulcano che spaziano dal bianco al nero passando da una nota riscaldata di lionato. Due le versioni della superficie: Inclusioni Soave mostra l'armonia dei materiali fusi nei toni e nelle forme, Inclusioni Extrafine è l'amalgama finale del complesso cromatico.

Inspired by the force of the nature, Inclusioni blends the intensity of color and the poetry of shape creating endless creative possibilities. Surfaces are authentically material and refined: porcelain stoneware flakes produced under the skilful control of our laboratory technicians are deposited on the surface and incorporated; the result is a tangible and three-dimensional effect. Five colours available: Bianco Perla, Ecrù, Tabacco, Cenere and Vulcano ranging from the white to black passing from a heated note of lionate. There are two versions available of the surface: Inclusioni Soave shows the harmony of the materials fused in tones and shapes, whilst Inclusioni Extrafine is the final amalgam of the chromatic complex.



Bianco Perla

Ecrù

Tabacco

Cenere

Vulcano



# Inclusioni



\* Disponibile nella superficie Bocciardato R10 e R11, specificare nell'ordine.  
Available Bocciardato R10 and R11 surface, specify in the order.

◆ Gli articoli con il marchio Gigacer Service saranno prodotti solo su specifica richiesta e quotati ove necessario (pag. 186).  
The products with the Gigacer Service label will be manufactured only upon specific request and they will be quoted where necessary (page 186).

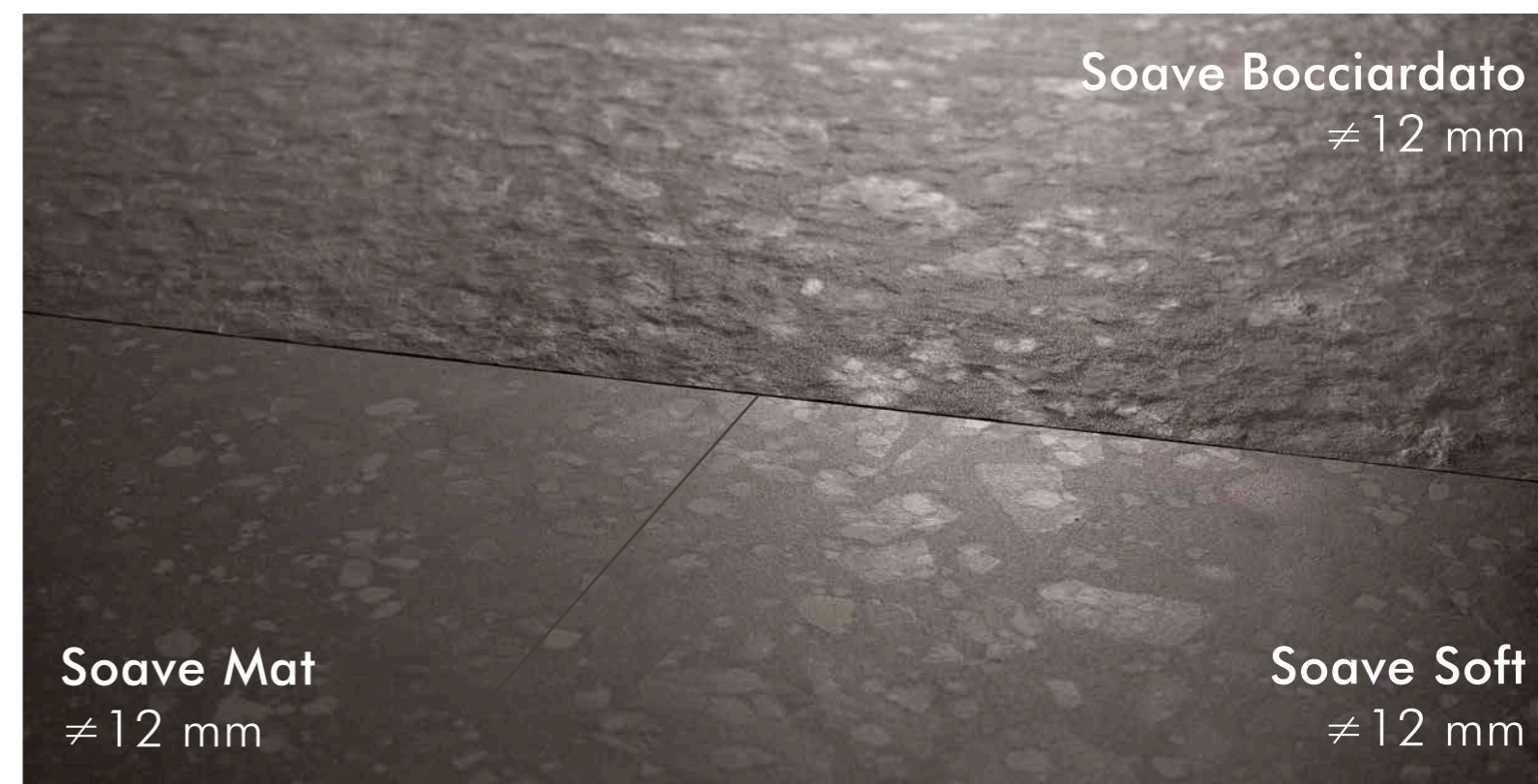
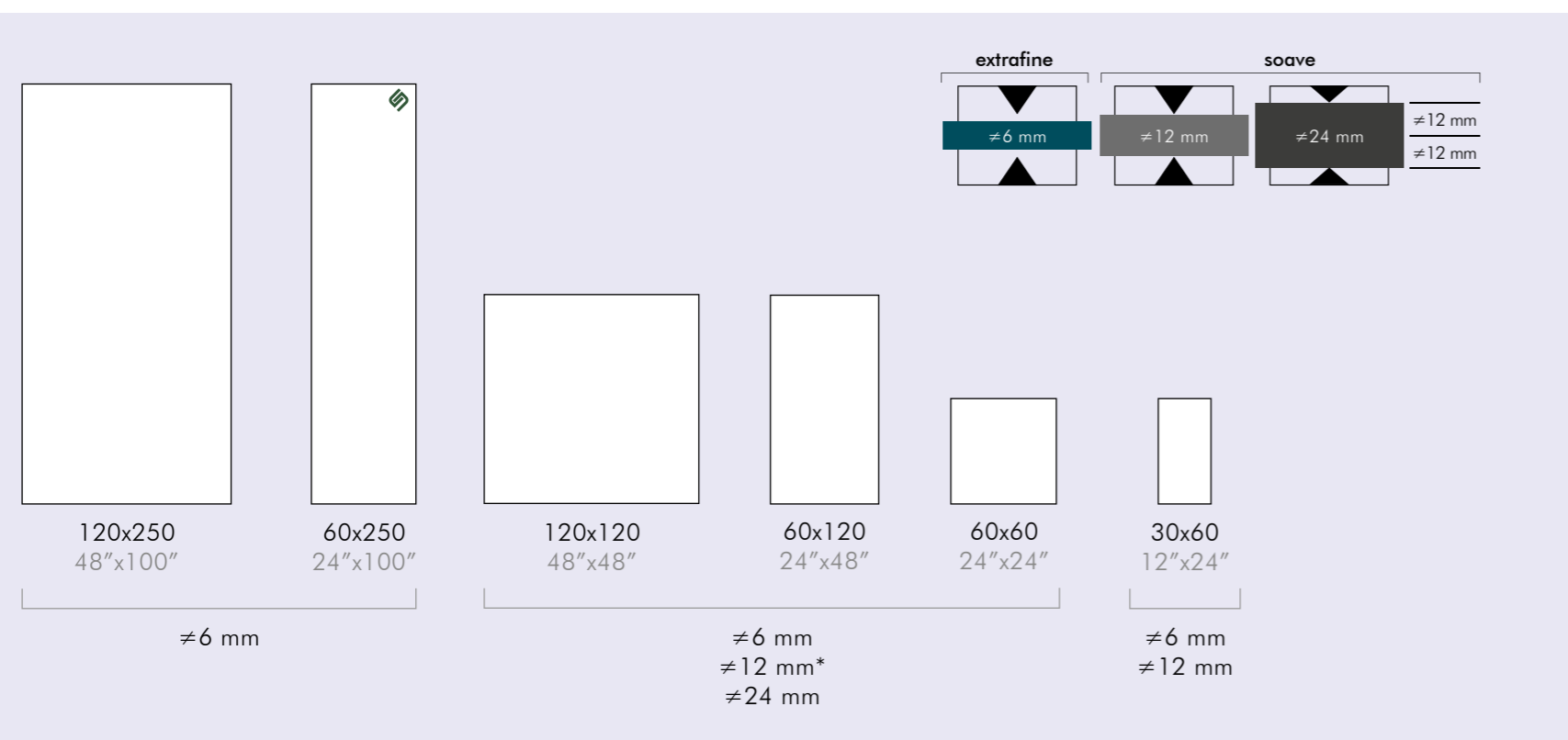

COLORE COLOUR	SUPERFICIE SURFACE	SPESSORE THICKNESS	120x250 48"x100"	60x250 24"x100"	120x120 48"x48"	60x120 24"x48"	60x60 24"x24"	30x60 12"x24"
Bianco Perla Ecrù Tabacco Cenere Vulcano	Extrafine Mat Extrafine Levigato	# 6	•	◆	•	•	•	•
Bianco Perla Ecrù Tabacco Cenere Vulcano	Soave Soft Soave Mat	# 12	-	-	•	•	•	•
Bianco Perla Ecrù Tabacco Cenere Vulcano	Soave Bocciardato R10 (Also in Bocciardato R11 anti-slip. Specify in the order).	# 12	-	-	•	•	•	-

- **Disponibile** Available
- **Non disponibile** Not available







**Parete | Wall**  
Ecrù Extrafine Mat Inclusioni  
120x250 cm · 48"x100" ≈6 mm

**Pavimento | Floor**  
(Indoor) Ecrù Soave Mat Inclusioni  
120x120 cm · 48"x48" ≈12 mm

(Outdoor) Ecrù Soave Bocciardato R11 Inclusioni  
120x120 cm · 48"x48" ≈12 mm



**Parete | Wall**  
Vulcano Extrafine Mat Inclusioni  
120x250 cm · 48"x100" ≈6 mm

**Vasca | Bathtub**  
Vulcano Extrafine Mat Inclusioni  
Gigacer Service ≈6 mm

**Pavimento | Floor**  
Vulcano Extrafine Mat Inclusioni  
120x250 cm · 48"x100" ≈6 mm





**Pavimento | Floor**  
Bianco Perla Soave Soft Inclusioni  
120x120 cm · 48"x48" ≠12 mm



**Pavimento | Floor**  
Tabacco Soave Mat Inclusioni  
120x120 cm · 48"x48" ≠12 mm



# Krea

Otto colori che interpretano la materia dei cementi e delle resine colorate in chiave moderna. La serie Krea consente di utilizzare colori vivaci e sfumature decise, oltre che in ambito residenziale, anche nei progetti pubblici, grazie alle elevate caratteristiche tecniche fornite dal gres porcellanato rigorosamente non smaltato. Una soluzione dal carattere deciso, adeguata all'abitare contemporaneo.

Eight colours that interpret cements and coloured resins in a modern way. Krea range allows you to use bright colors and bold shades both in residential and in public projects, thanks to the high technical characteristics provided by the unglazed porcelain stoneware. A solution with a decisive character, suitable for contemporary living.



Ground

Nut

Silver

Snow

Red

Orange

Green

Blue



# Krea



La struttura superficiale, sia nello spessore 4,8mm/6mm che nel 12mm, è la stessa di Concrete. È quindi possibile combinare le due serie, entrambe rettificate e monocalibro, in tutti i formati disponibili. The surface texture is the same as in Concrete, both in 4,8mm/6mm and 12mm thickness. It is therefore possible to combine the two ranges, both rectified in the same calibre, in all available formats.

**\*\*Disponibile il formato 120x250 e 60x250 nei colori:** Available sizes 120x250 and 60x250 in colours: **Ground, Nut, Silver, Snow, Orange, Green e Blue.**

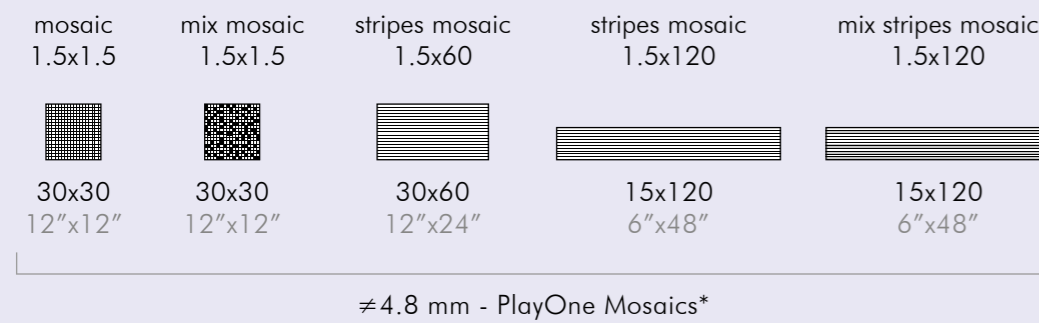
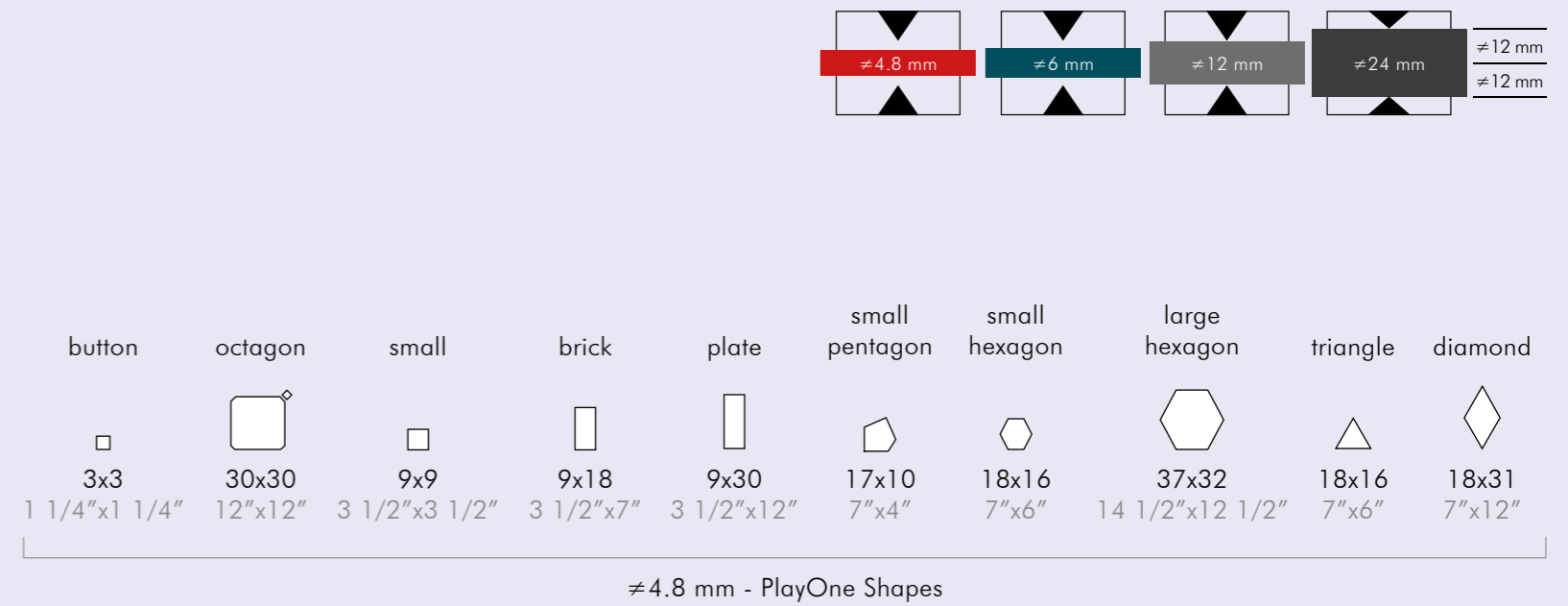
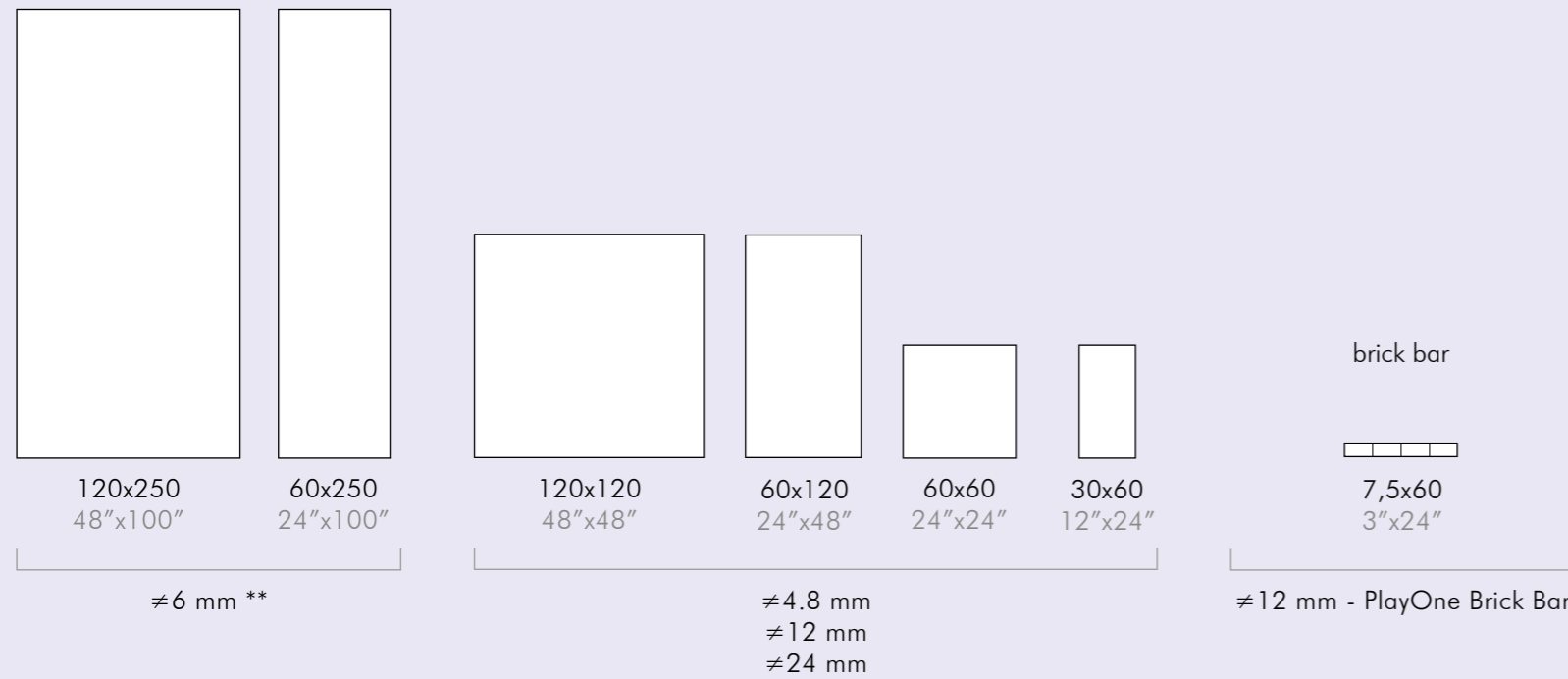

**\*Mosaici forniti su rete**  
Mosaics are mesh-mounted





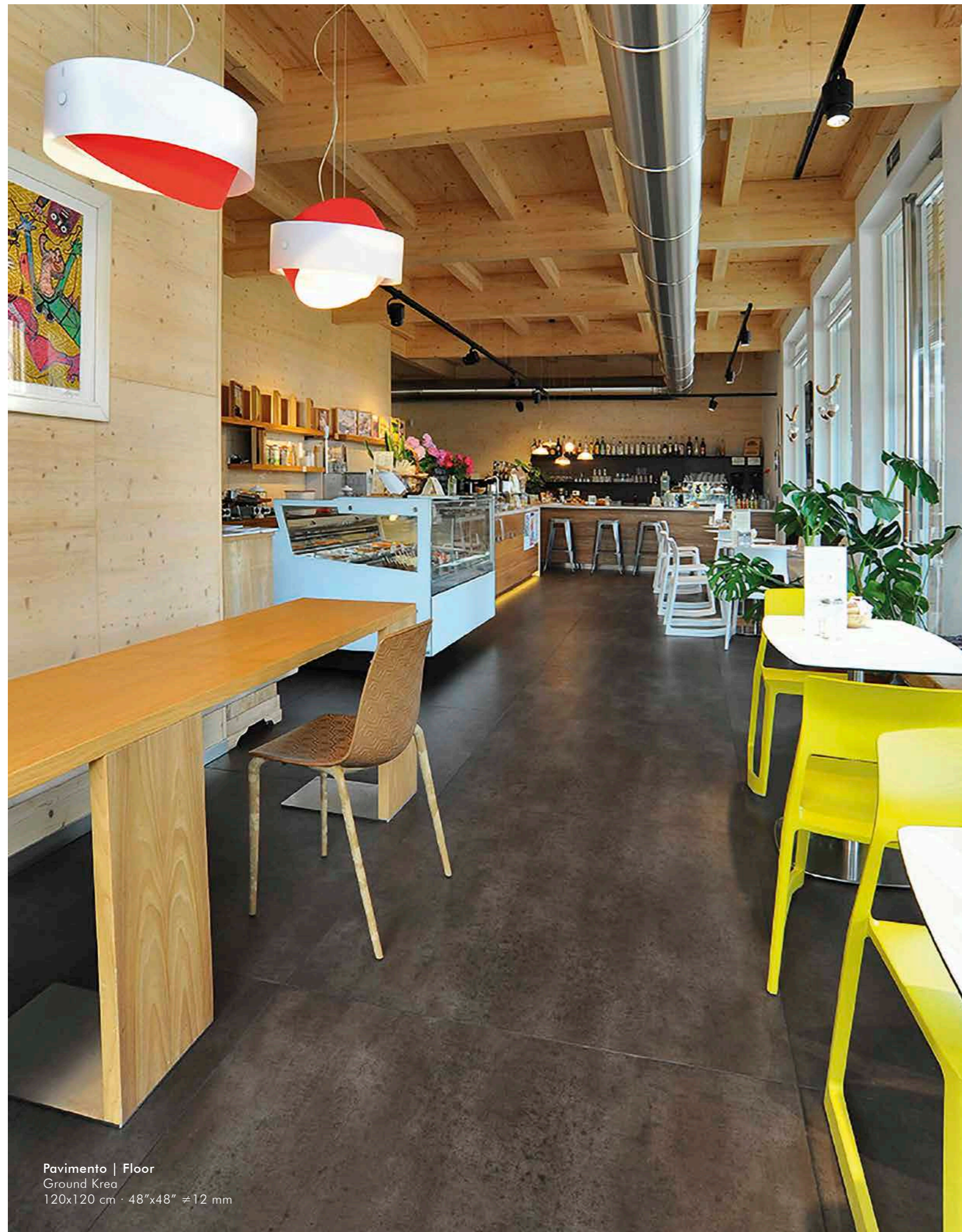

Pavimento | Floor  
Ground Krea  
120x120 cm · 48"x48" ≈12 mm



Parete | Wall  
Blue Krea  
60x120 cm · 24"x48" ≈4.8 mm

Pavimento | Floor  
Silver Krea  
120x120 cm · 48"x48" ≈12 mm





**Parete | Wall**  
Red / Green / Snow Krea  
Small Hexagon  
18x16 cm · 7"x6" ≈4.8 mm

Snow / Green Krea  
Brick Bar  
7,5x60 cm · 3"x24" ≈12 mm

Orange / Ground Krea  
Large Hexagon  
36x31 cm · 14"x12" ≈4.8 mm

**Pavimento | Floor**  
Ground Krea  
120x250 cm · 48"x100" ≈6 mm



**Parete | Wall**  
Orange / Ground Krea  
Large Hexagon  
36x31 cm · 14"x12" ≈4.8 mm

**Pavimento | Floor**  
Ground Krea  
120x120 cm · 48"x48" ≈12 mm



# Light

Un innovativo sistema di materiali in gres porcellanato che gioca con la luce e con la materia: LIGHT. È la luce ad evidenziare la struttura materica delle otto superfici, esaltandone la varietà plastica espressiva. Light è anche la materia: leggera, perché questa gamma completamente bianca è formata da uno spessore sottile di pura materia candida.

An innovative system of white porcelain stoneware materials centered on light and on texture: LIGHT. It is light that transforms these eight textural surfaces, enhancing their expressive variety. Light is also the material: light, because this completely white range is composed by a thin thickness of pure white matter.





# Light

Le 5 superfici nel formato Blend 20x20/15x60 sono vendute in scatole già miscelate.  
The 5 surfaces in Blend 20x20/15x60 size are sold in pre-mixed packages.

# Light 250



**Rectangular Tiles:**

- 120x120 (48"x48")
- 60x120 (24"x48")
- 60x60 (24"x24")
- 30x60 (12"x24")
- 15x60 (6"x24")
- 20x20 (8"x8")
- brick bar (7,5x60 / 3"x24")

**PlayOne Shapes (6 mm):**

- button (3x3 / 1 1/4"x1 1/4")
- octagon (30x30 / 12"x12")
- small (9x9 / 3 1/2"x3 1/2")
- brick (9x18 / 3 1/2"x7")
- plate (9x30 / 3 1/2"x12")
- small pentagon (17x10 / 7"x4")
- small hexagon (18x16 / 7"x6")
- large hexagon (37x32 / 14 1/2"x12 1/2")
- triangle (18x16 / 7"x6")
- diamond (18x31 / 7"x12")

**PlayOne Mosaics\* (6 mm):**

- mix mosaic 1.5x1.5 (30x30 / 12"x12")
- mix mosaic 3x3 (30x30 / 12"x12")
- mix mosaic 3x6 (30x30 / 12"x12")
- mix stripes mosaic 1.5x120 (15x120 / 6"x48")
- mix 3d mosaic (30x17 / 12"x6 1/2")

**Blend Packages (6 mm):**

- blend 20x20 (20 pz): Rigato, Gesso, Crespo, Roccia, Scolpito
- blend 15x60 (16 pz): Rigato, Gesso, Crespo, Roccia, Scolpito

**Thicknesses:**

- 6 mm (most shapes)
- 12 mm (solo/only Gesso)

**Rectangular Tiles (6 mm):**

- 120x250 (48"x100")
- 60x250 (24"x100")
- 120x120 (48"x48")
- 60x120 (24"x48")
- 30x60 (12"x24")

**Thickness:** 6 mm



\*Mosaici forniti su rete  
Mosaics are mesh-mounted

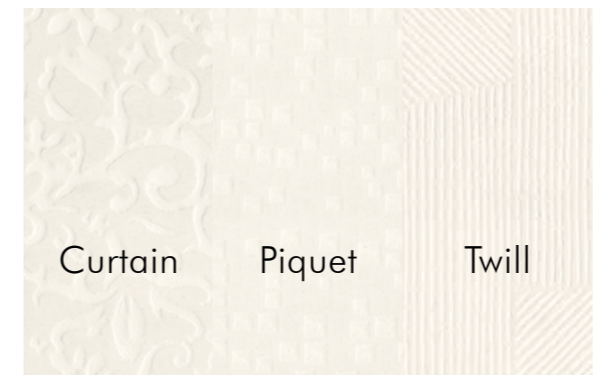



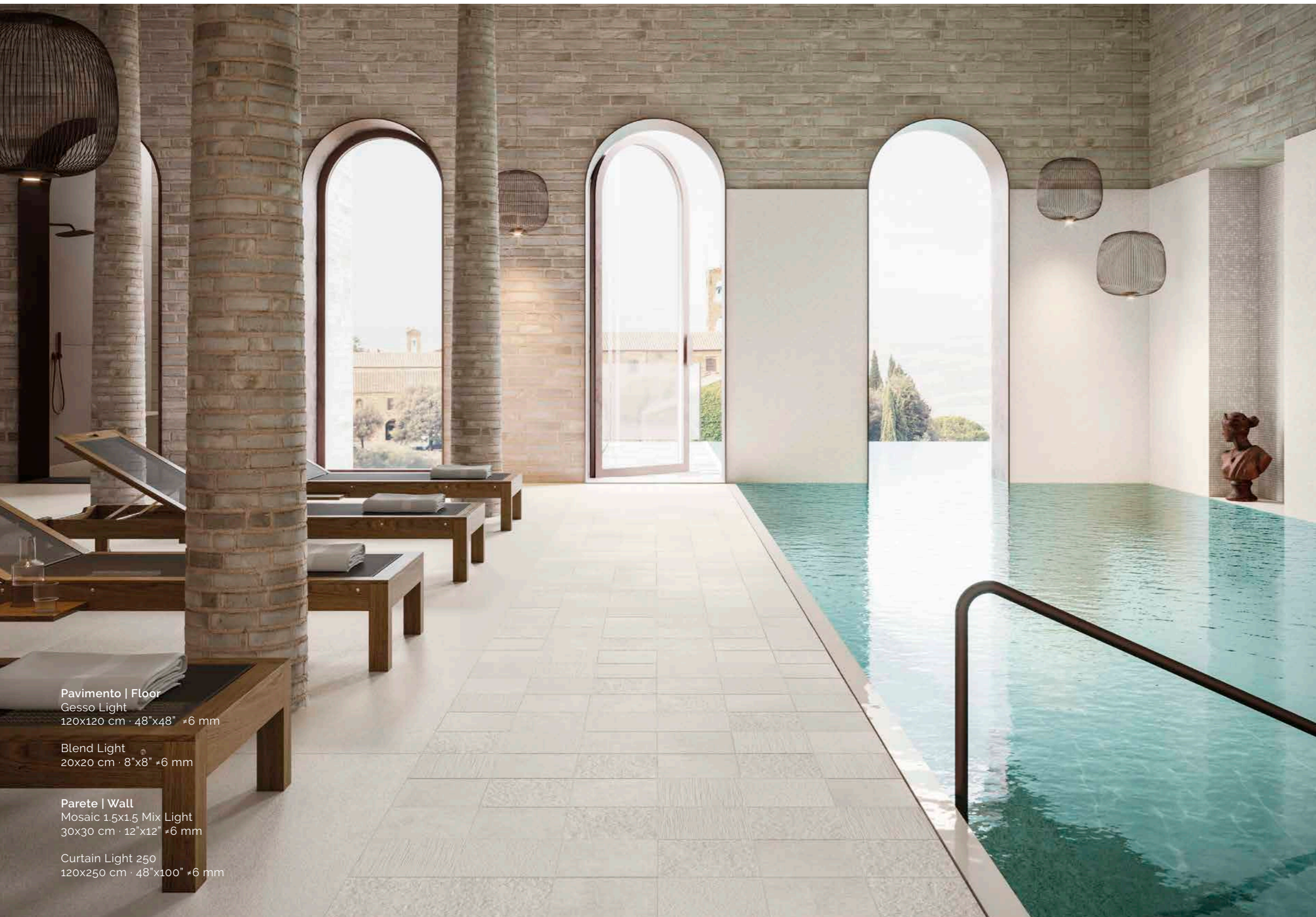

Pavimento | Floor  
Gesso Light  
120x120 cm · 48"x48" +6 mm

Blend Light  
20x20 cm · 8"x8" +6 mm

Parete | Wall  
Mosaic 1.5x1.5 Mix Light  
30x30 cm · 12"x12" +6 mm

Curtain Light 250  
120x250 cm · 48"x100" +6 mm

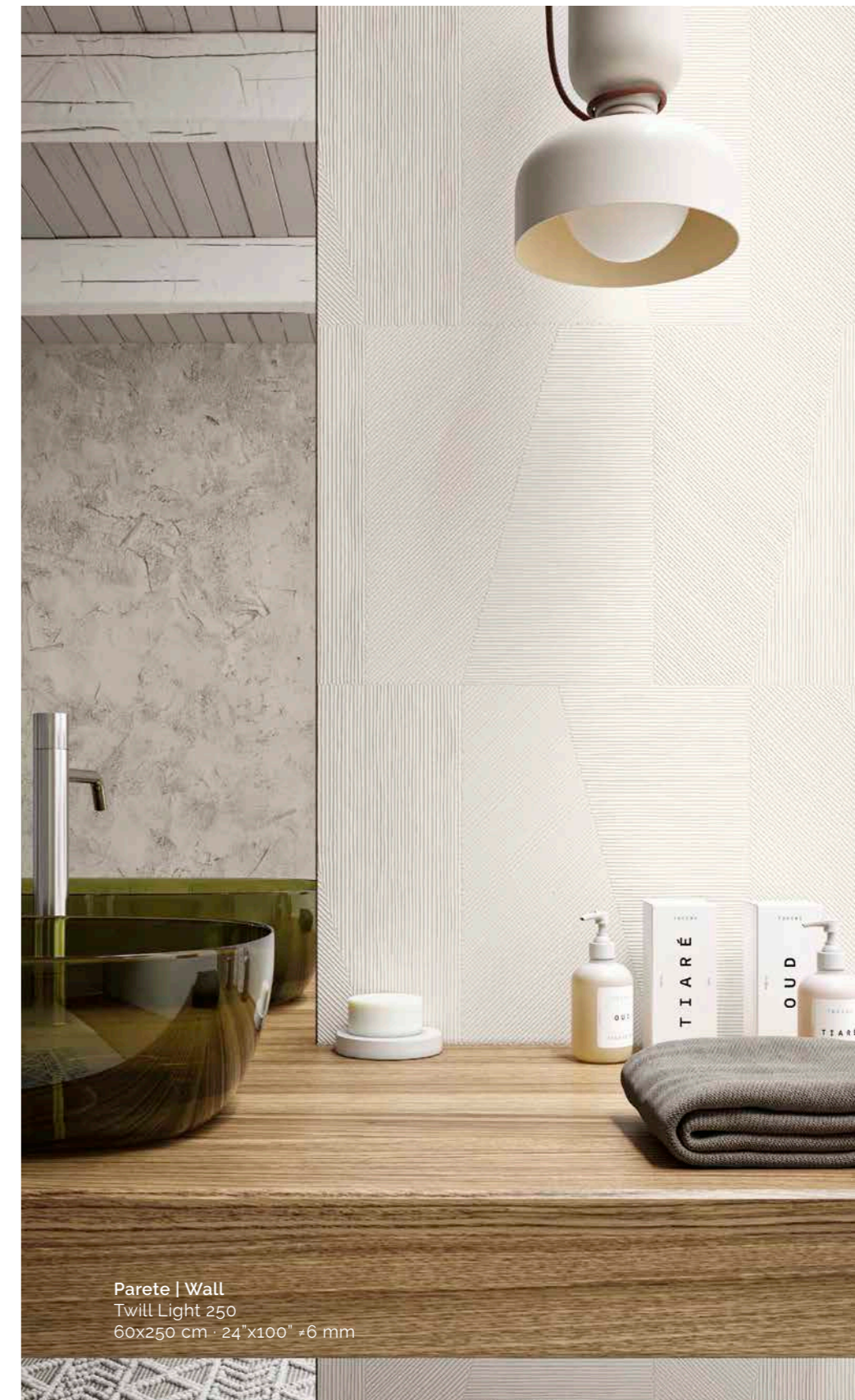

Parete | Wall  
Twill Light 250  
60x250 cm · 24"x100" +6 mm





**Parete | Wall**  
Curtain / Piquet / Twill Light 250  
120x250 cm · 48"x100" ≠6 mm

**Ice Concrete**  
Gigacer Service ≠6 mm

**Piano cucina | Kitchen top**  
Mud Concrete  
Gigacer Service ≠6 mm

**Pavimento | Floor**  
Gesso Light  
120x120 cm · 48"x48" ≠12 mm



**Parete | Wall**  
Blend Light  
20x20 cm · 8"x8" ≠6 mm

**Pavimento | Floor**  
Blend Light  
15x60 cm · 6"x24" ≠6 mm

Gesso Light  
60x120 cm · 24"x48" ≠6 mm



# Made 2.0

Made 2.0, in sinergia con Concrete (pag. 22), è un flessibile sistema ceramico a servizio degli spazi abitativi. È la paletta di combinazione colori/superfici più completa nelle tinte neutre e naturali: undici colori e quattro diverse superfici che si adattano alle diverse esigenze dell'abitare. Lo stesso colore può essere utilizzato dall'interno all'esterno, nei pavimenti e nei rivestimenti e per la realizzazione di piani cucina e mobili da bagno mantenendo una forte coerenza cromatica. Tutta la paletta Made 2.0 corrisponde ai colori Concrete. Il colore White Sand equivale al Concrete White.

Made 2.0, in synergy with Concrete (page 22), is a flexible ceramic system used for living spaces. It is the most complete color / surface combination palette in neutral and natural shades: eleven colours and four different surface that could be adapted to the different needs of living. The same colour could be used from the indoor to the outdoor, in floors and covering and for the creation of kitchen tops and bathroom furniture while maintaining a strong chromatic coherence. All the Made 2.0 Palette corresponds to the Concrete colours. The White Sand colour can be combined with the Concrete White.

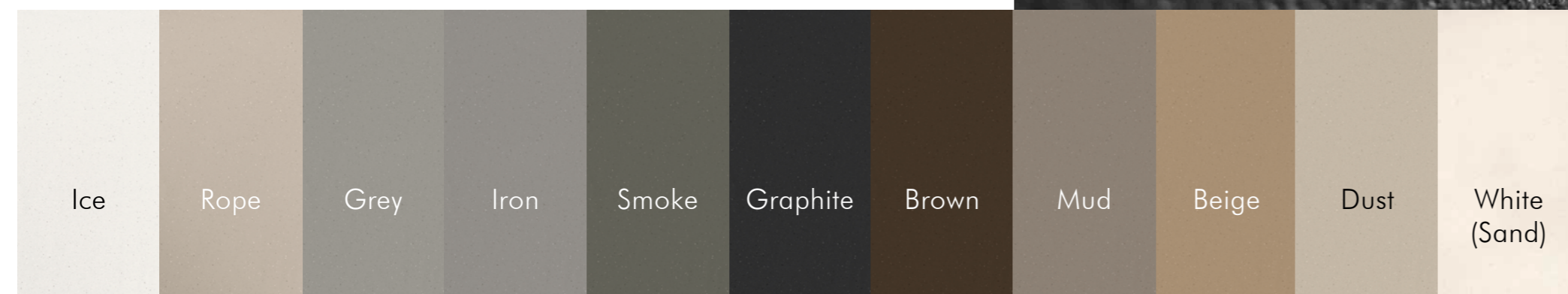



# Made 2.0



Tutti i colori Made 2.0 corrispondono ai colori Concrete. Il colore White Sand si abbina al Concrete White.  
 All Made 2.0 colours correspond to Concrete colours. Made White Sand matches Concrete White.

°Mix Concrete e Made 2.0 Bocciardato  
 °Mix Concrete and Made 2.0 Bocciardato

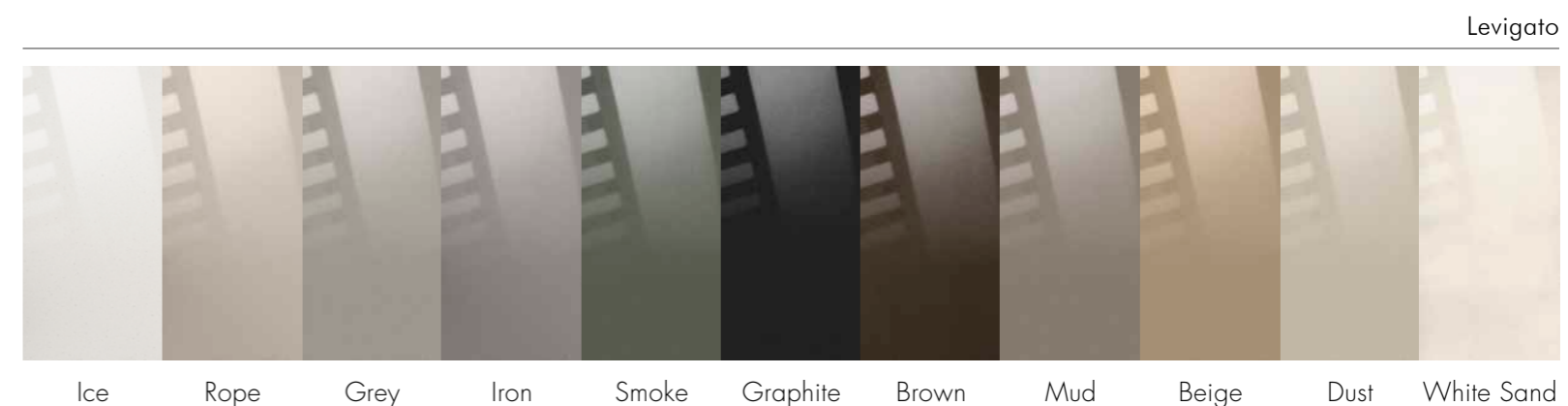
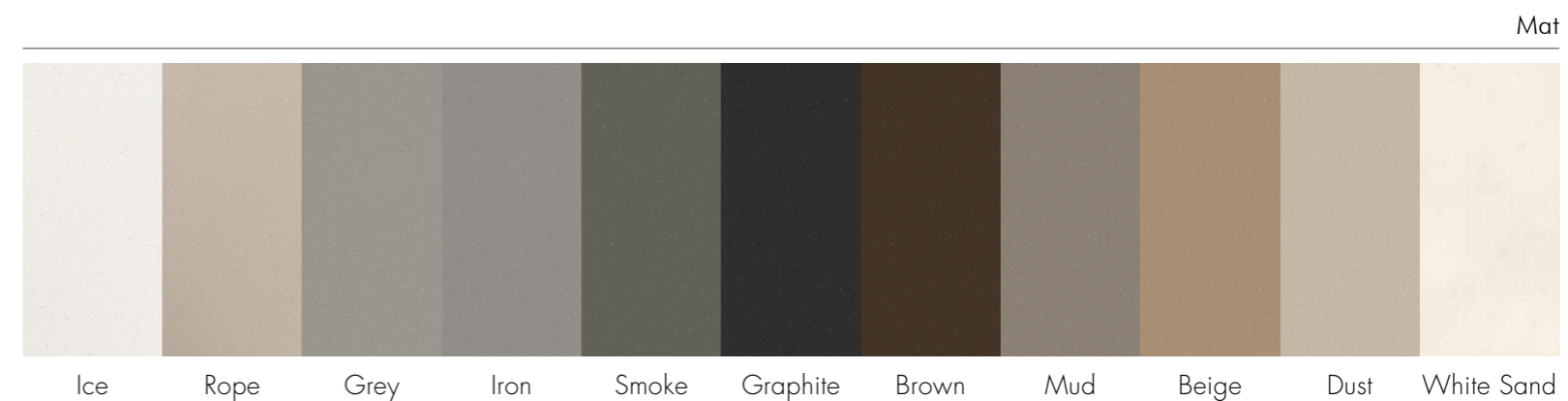
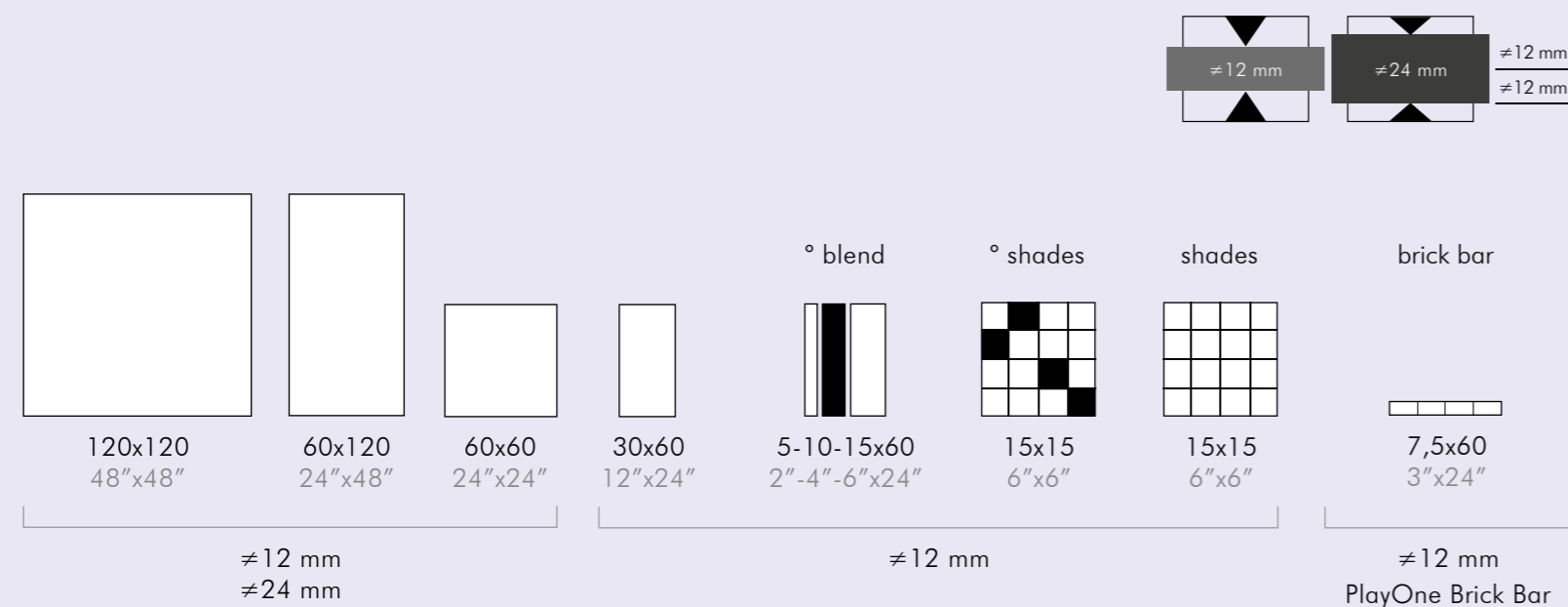

° Blend



° Shades

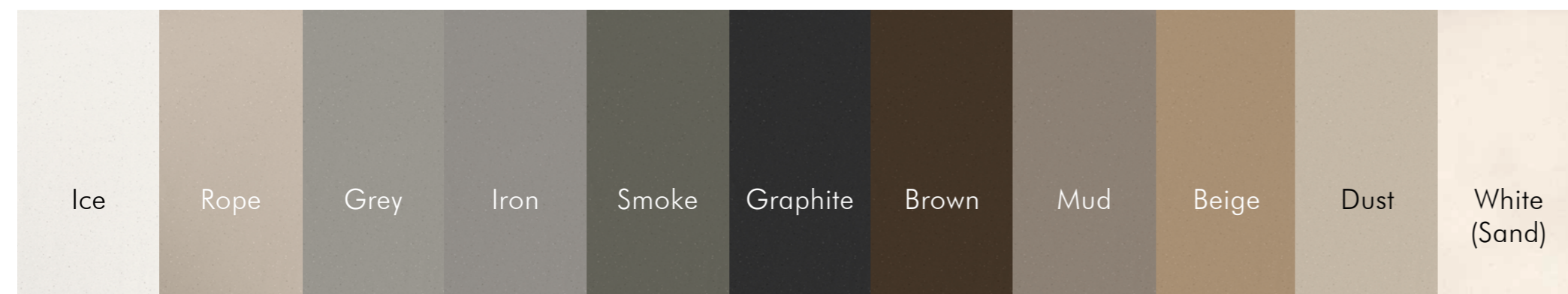





Pavimento | Floor  
White Sand Mat Made 2.0  
120x120 cm · 48"x48" ±12 mm

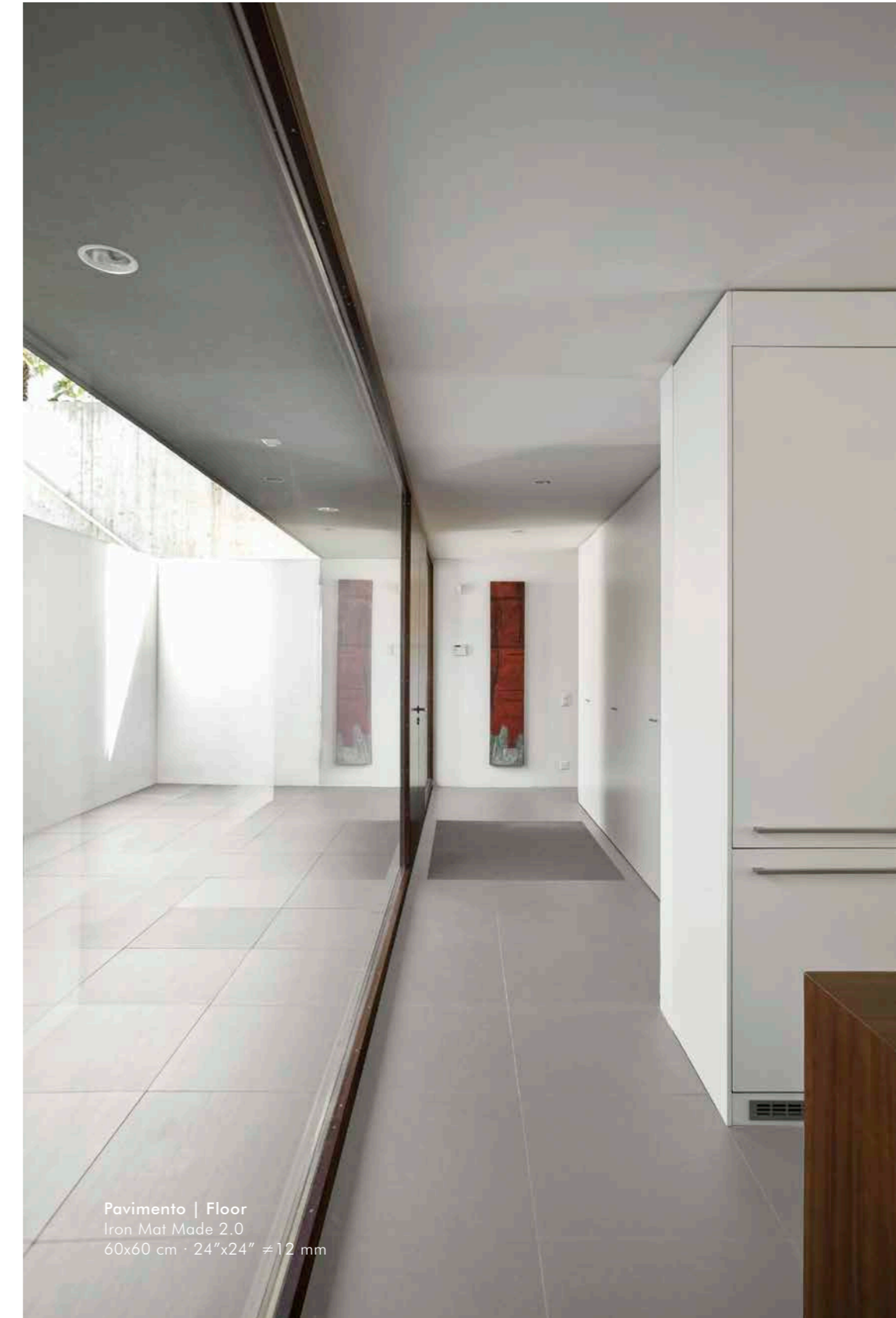

Pavimento | Floor  
Iron Mat Made 2.0  
60x60 cm · 24"x24" ±12 mm





Scale | Stairs  
Graphite Bocciardato Made 2.0  
Gigacer Service  $\neq$  12 mm



Pavimento | Floor  
Graphite Bocciardato R11 Made 2.0  
60x60 cm · 24"x24"  $\neq$  12 mm



# Quarry

Quarry reinterpreta in chiave tecnica la solida forza di sei pietre tipicamente europee. La prima pietra ispiratrice è la Quarzite Bianca, da cui prende il nome e il colore. Diffusa nelle catene montuose delle Prealpi, Arenaria interseca vene bianche al colore grigio. Gravel Stone richiama la pietra del Cardoso, le cui cave sono ubicate in prossimità del paese toscano. Lava Stone arriva dal Belgio, con una nuance scura. La Spagna è l'origine di Crema Marfil, una pietra dal colore beige a sfondo uniforme. Infine Golden Stone si ispira alla pietra fossile tedesca Solnhofen ed è proposta nel tono caldo del materiale originale.

Quarry reinterprets the solid power of six typically European stones in a technical way. The first stone inspiring us is Quarzite Bianca (white quartzite), the origin of its name and colour. Common in the Alpine foothills, Arenaria (sandstone) is grey in colour shot through with white veins. Gravel Stone brings to mind Cardoso stone with quarries near this Tuscan town. Lava Stone comes from Belgium and is dark. Spain is the origin of Crema Marfil, a homogeneous beige coloured stone. Lastly Golden Stone takes its inspiration from the Solnhofen German fossil stone and is offered in the warm hues of the original material.

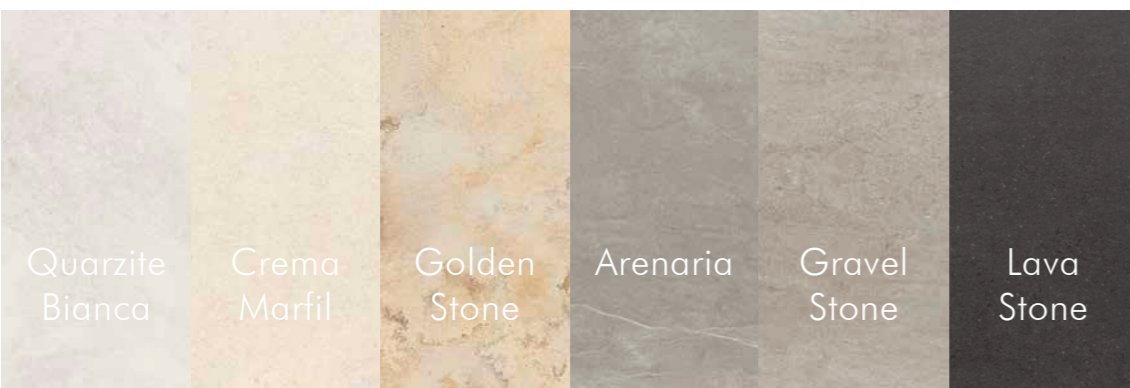



# Quarry



\*Disponibile nei colori solo nella superficie Mat: Available in colours only in the mat surface:  
Quarzite Bianca, Crema Marfil, Gravel Stone, Lava Stone.

\*\*Mosaico Mix: Mat + Bocciardato Antiscivolo R11. Mosaico Mix: Mat + Bocciardato Antislip R11.

\*\*\* Disponibile solo in superficie Mat. Available only in Mat surface.

Tutti i colori e i formati sono disponibili in due finiture: MAT R10 A+B e BOCCIARDATO ANTISCIVOLO R11 A+B+C.  
All colours and sizes are available in two surfaces: MAT R10 A+B and BOCCIARDATO ANTISLIP R11 A+B+C.

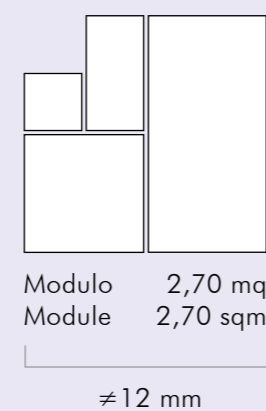
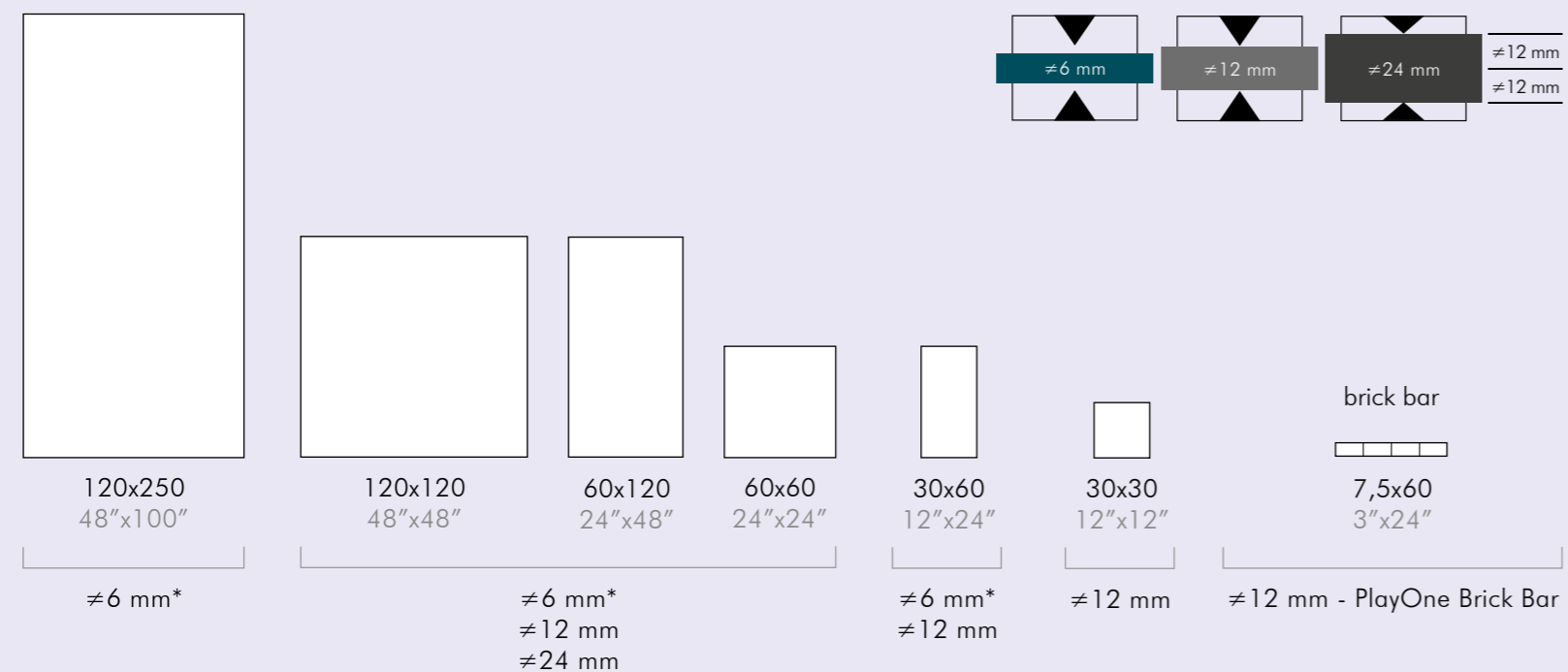

Ogni modulo, composto da 2 pezzi di 60x120, 2 pezzi di 60x60, 2 pezzi di 30x60 e 2 pezzi di 30x30, è contenuto in un'unica scatola. Each module, that is composed of 2 pieces of 60x120, 2 pieces of 60x60, 2 pieces of 30x60 and 2 pieces of 30x30, is packed in a single box.



Mosaici forniti su rete  
Mosaics are mesh-mounted





**Pavimento | Floor**  
Arenaria Mat Quarry  
Modulo/Module: 60x120 cm · 24"x48" · 60x60 cm · 24"x24" · 30x60 cm · 12"x24" · 30x30 cm · 12"x12" ≠12 mm  
Arenaria Bocciardato R11 Quarry  
120x120 · 48"x48" ≠12 mm



**Parete | Wall**  
Gravel Stone Mat Quarry  
120x120 cm · 48"x48" ≠12 mm

**Pavimento | Floor**  
Gravel Stone Mat Quarry  
120x120 cm · 48"x48" · 60x120 cm · 24"x48" ≠12 mm





**Parete | Wall**  
Golden Stone Mat Quarry  
120x120 cm · 48"x48" ≠12 mm

**Pavimento | Floor**  
Golden Stone Bocciardato R11 Quarry  
Modulo/Module:  
60x120 cm · 24"x48" · 60x60 cm · 24"x24" · 30x60 cm · 12"x24" · 30x30 cm · 12"x12" ≠12 mm



**Parete | Wall**  
Quarzite Bianca Mat Quarry  
120x120 cm · 48"x48" ≠12 mm

**Pavimento | Floor**  
Quarzite Bianca Mat Quarry  
Modulo/Module:  
60x120 cm · 24"x48" · 60x60 cm · 24"x24"  
30x60 cm · 12"x24" · 30x30 cm · 12"x12" ≠12 mm



Les Couleurs Suisse AG di Zurigo detiene i diritti in esclusiva mondiale sul sistema unico "Polychromie architecturale" di Le Corbusier e ha concesso a Gigacer Spa la licenza d'uso dei colori originali Les Couleurs® Le Corbusier sulle collezioni denominate LCS Ceramics, gres per l'architettura. LCS Ceramics è il primo sistema colore prodotto da Gigacer basato sulla Polychromie architecturale di Le Corbusier. Innovativi materiali in gres porcellanato ideati per pavimentare e rivestire l'architettura.

Les Couleurs Suisse AG of Zurich holds the exclusive international rights to Le Corbusier's unique "Polychromie architecturale" system and has granted Gigacer Spa the licence to use the original Les Couleurs® Le Corbusier colours in its collections LCS Ceramics, porcelain stoneware for architecture. LCS Ceramics is the first Gigacer colour system based on Le Corbusier's Architectural Polychromy. Innovative materials in porcelain stoneware for architecture.

Charles-Edouard Jeanneret-Gris, conosciuto con lo pseudonimo di Le Corbusier (1887-1965) è considerato il più importante architetto dell'era moderna. Ancora oggi le sue opere influenzano autorevolmente l'architettura e il design. Ha progettato moltissimi edifici e numerosi piani di sviluppo urbano in tutto il mondo, e oggi buona parte delle sue architetture sono state riconosciute dall'Unesco patrimonio dell'umanità. Le Corbusier ha lavorato in numerosi campi artistici dando vita ad una serie di opere quali dipinti, sculture, disegni e collage, smalti, arazzi, incisioni e oggetti d'arredo dal design inconfondibile, divenuti vere e proprie icone. Per Le Corbusier gli aspetti cromatici dei suoi edifici o dei suoi oggetti di design erano tanto importanti quanto la pianta e la forma. Affascinato dai colori equilibrati della natura, Le Corbusier diede vita alla "Polychromie architecturale" basandosi su una selezione progettuale e artistica di pigmenti.

Charles-Edouard Jeanneret-Gris, better known by the pseudonym Le Corbusier (1887-1965), is considered the most important architect of the modern age. His works still have a considerable influence on architecture and design today. He designed many buildings and drew up numerous urban development plans throughout the world and today the majority of his architecture has been recognised by Unesco as World Heritage. Le Corbusier was an all-round artist, producing a large number of artworks such as paintings, sculptures, drawings and collages, enamels, tapestries, engravings and furniture, all with the same unmistakable design and which have become real icons. The colour schemes of his buildings and design objects were just as important to Le Corbusier as the ground plan and shape. Fascinated by the balanced colours he found in nature, Le Corbusier based his "Architectural Polychromy" on a structured and artistic choice of pigments.

# Le Corbusier

LCS Ceramics

Based on Le Corbusier's  
Polychromie architecturale

A worldwide exclusive



## / LCS COLLECTIONS

Béton

LCS 1 / LCS 2

Tokyo

Molitor

Pointillé



# Béton

## Il cemento in architettura.

Traendo ispirazione dai molteplici edifici di Le Corbusier circa l'utilizzo del cemento a vista, Gigacer ha realizzato Béton Gris e Béton Blanc, superfici in grès ceramico dai toni neutri che riprendono il carattere minimalista insito nel famoso Beton Brut. La gamma è ideale per utilizzi a pavimento e rivestimento di ambienti sia residenziali che pubblici e trova una naturale abbinabilità con i colori LCS Ceramics Le Corbusier.

## Concrete in architecture.

Taking inspiration from the many buildings designed by Le Corbusier where he used exposed concrete, Gigacer has created Béton Gris and Béton Blanc, neutral ceramic porcelain surfaces which are reminiscent of the minimalist character of the famous Béton Brut. The range is ideal for wall and floor coverings for residential and public use and can be perfectly combined with the Le Corbusier LCS Ceramics colours.



Unite d'Habitation - Marseille - 1945 ©



Blanc

Gris



# Béton

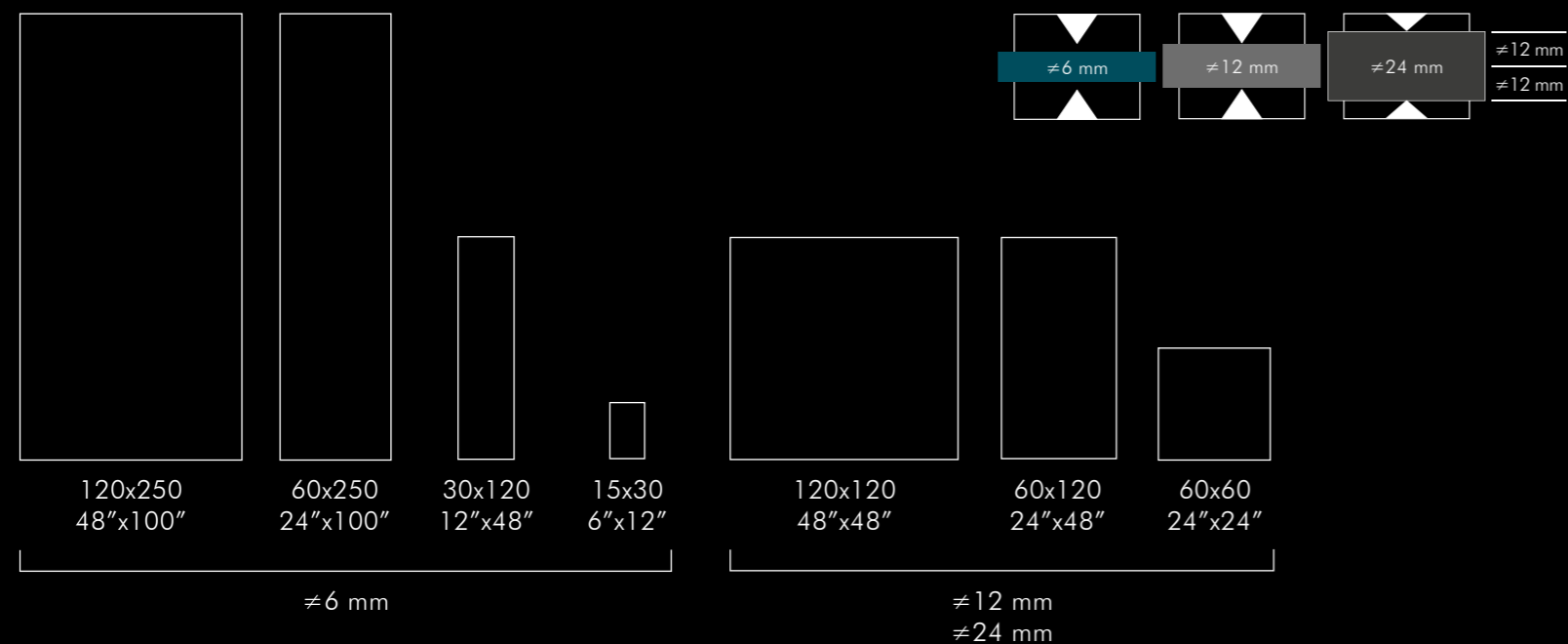



# LCS

LCS 1. Gres porcellanato smaltato, lucido, brillante. Ideale per utilizzi a rivestimento in ambienti sia interni che esterni.

LCS 2. Realizzata su supporto Beton Blanc e caratterizzata da incisioni lineari a bassorilievo nei 6 toni colore LCS1: Gris Clair 31, Bleu outremer 59, Rouge vermillon 59, Noir d'ivoire, Vert 59, Le jaune vif. LCS2 ha finitura matt ed e ideale per utilizzi a pavimento e rivestimento.

LCS 1. Glazed porcelain stoneware, glossy, brilliant. Ideal for indoor and outdoor wall coverings.

LCS 2. Produced on a Beton Blanc support, it features linear bas relief engravings in the 6 LCS1 color shades: Gris clair 31, Bleu outremer 59, Rouge vermillon 59, Noir d'ivoire, Vert 59, Le jaune vif. LCS2 has a matt finish and is the ideal solution for wall and floor coverings.



Maison des Jeunes et de la Culture - Firminy France - 1953 ©



32001 blanc	32013 gris clair 31	32020 bleu outremer 31	32023 outremer pâle	32034 céruleen pâle	32123 terre sienne pâle	32142 ombre naturelle claire	4320A rouge vermillon 59	4320B blanc ivoire	4320E noir d'ivoire	4320G vert 59	4320W le jaune vif	32013 gris clair 31	32020 bleu outremer 31	4320A rouge vermillon 59	4320E noir d'ivoire	4320G vert 59	4320W le jaune vif
----------------	------------------------	------------------------------	------------------------	------------------------	-------------------------------	------------------------------------	--------------------------------	-----------------------	------------------------	------------------	-----------------------	------------------------	------------------------------	--------------------------------	---------------------------	------------------	-----------------------



# LCS 1 -glossy



30x120  
12"x48"

≠6 mm



**Parete | Wall**

32034 - Céruléen Pâle - LCS 1  
30x120 cm · 12"x48" ≠6 mm

32123 - Terre Sienne Pâle - LCS 1  
30x120 cm · 12"x48" ≠6 mm

Béton Blanc  
120x250 cm · 48"x100" ≠6 mm

32001  
blanc

32013  
gris clair 31

32020  
bleu  
outremer 31

32023  
outremer pâle

32034  
céruléen pâle

32123  
terre sienne  
pâle

32142  
ombre  
naturelle claire

4320A  
rouge vermillon  
59

4320B  
blanc ivoire

4320E  
noir d'ivoire

4320G  
vert 59

4320W  
le jaune vif



# LCS2-line



30x120  
12"x48"

≠6 mm



**Parete | Wall**  
All colours - LCS 2  
30x120 cm · 12"x48" ≠6 mm

Béton Blanc  
120x250 cm · 48"x100" ≠6 mm



32013  
gris clair 31

32020  
bleu  
ouatremer 31

4320A  
rouge vermillon  
59

4320E  
noir  
d'ivoire

4320G  
vert 59

4320W  
le jaune vif



# Tokyo

È l'unico esempio rappresentativo del lavoro di Le Corbusier in Estremo Oriente, e la recensione del New York Times sulla sua apertura suggeriva che l'edificio stesso presentava un "significato artistico e bellezza" che rivaleggiava con i dipinti all'interno. Il museo è a pianta quadrata con il corpo principale delle gallerie sollevate su "pilotis" al primo piano. Il layout è influenzato dal museo Sanskar Kendra di Le Corbusier ad Ahmedabad, progettato allo stesso tempo. Sulla facciata principale, Le Corbusier ha utilizzato blocchi di ghiaia cementata anziché calcestruzzo grezzo, e abbiamo tratto ispirazione da questa innovazione per sviluppare la nostra gamma Tokyo.

It is the only representative example of Le Corbusier's work in the Far East, and the New York Times review of its opening suggested that the building itself presented an "artistic significance and beauty" which rivaled the paintings inside. The museum is square in plan with the main body of the galleries raised on "pilotis" to first floor level. The layout is influenced by Le Corbusier's Sanskar Kendra museum in Ahmedabad which was being designed at the same time. On the main facade, Le Corbusier used blocks of cemented gravel instead of raw concrete, and we took inspiration from this innovation to develop our Tokyo range.



The National Museum of Fine Arts of the West - Tokyo - 1955 ©





# Tokyo

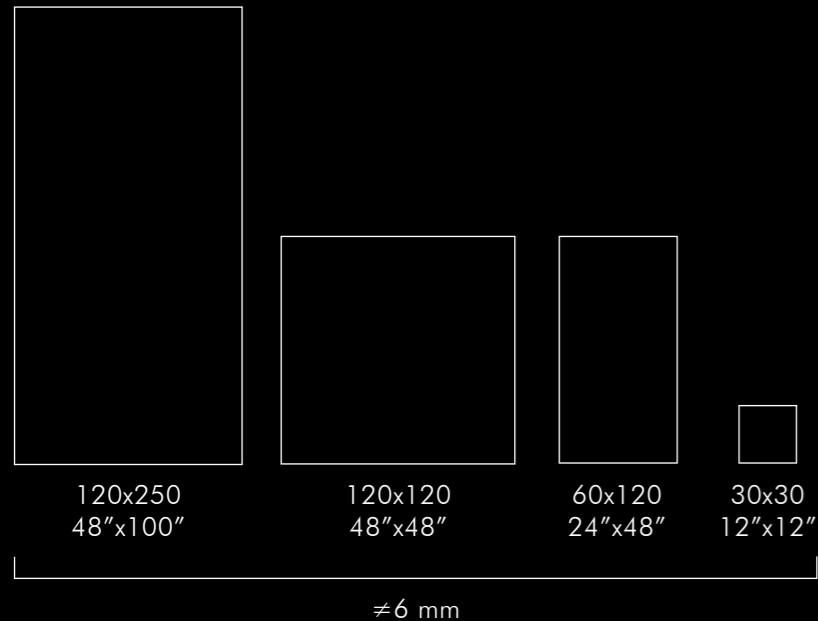

Mensola | Shelf  
4320E - Noir d'Ivoire - Tokyo  
Gigacer Service ≠6 mm





# Molitor

Immeuble Molitor è un condominio progettato da Le Corbusier e Pierre Jeanneret e costruito tra il 1931 e il 1934. Situato al confine tra la città di Parigi e il comune di Boulogne-Billancourt in Francia, è stato elencato insieme ad altre 16 opere architettoniche di Le Corbusier come patrimonio mondiale dell'UNESCO. L'inventiva dell'architetto è evidente nelle facciate interamente in vetro. Identiche in entrambe le altezze, contemporanee alla Maison de Verre di Bernard Bijvoet, ma Le Corbusier partì dal prototipo di soli mattoni di vetrocemento con l'aggiunta di aperture trasparenti. Esternamente le facciate offrono un contrasto tra mattoni in vetro massiccio e finestre trasparenti, ma internamente gli appartamenti sono inondati di luce attraverso l'intera parete.

Immeuble Molitor is an apartment building designed by Le Corbusier and Pierre Jeanneret and built between 1931 and 1934. Located at the border between the city of Paris and the commune of Boulogne-Billancourt in France, it has been listed along with 16 other architectural works by Le Corbusier as a UNESCO World Heritage Site. The architect's inventiveness is evident in the all-glass facades. Identical on both elevations, contemporary to Bernard Bijvoet's Maison de Verre, but Le Corbusier departed from glass-brick-only prototype by the addition of transparent openings. Externally the facades offer a contrast between solid glass bricks and transparent windows, but internally the apartments are flooded with light across the entire wall.



Immeuble Molitor - Paris - 1934 ©



32140  
ombre  
naturelle 31

32141  
ombre  
naturelle  
moyenne

32142  
ombre  
naturelle  
claire

32013  
gris clair 31

32011  
gris 31

32010  
gris foncé 31



# Molitor

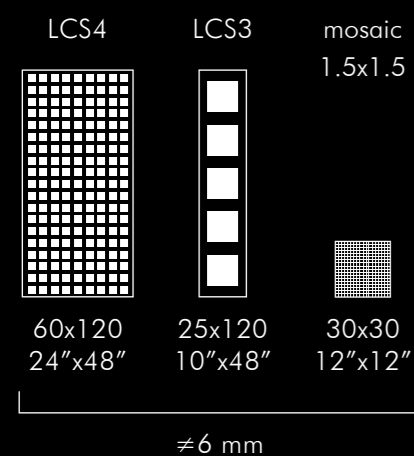
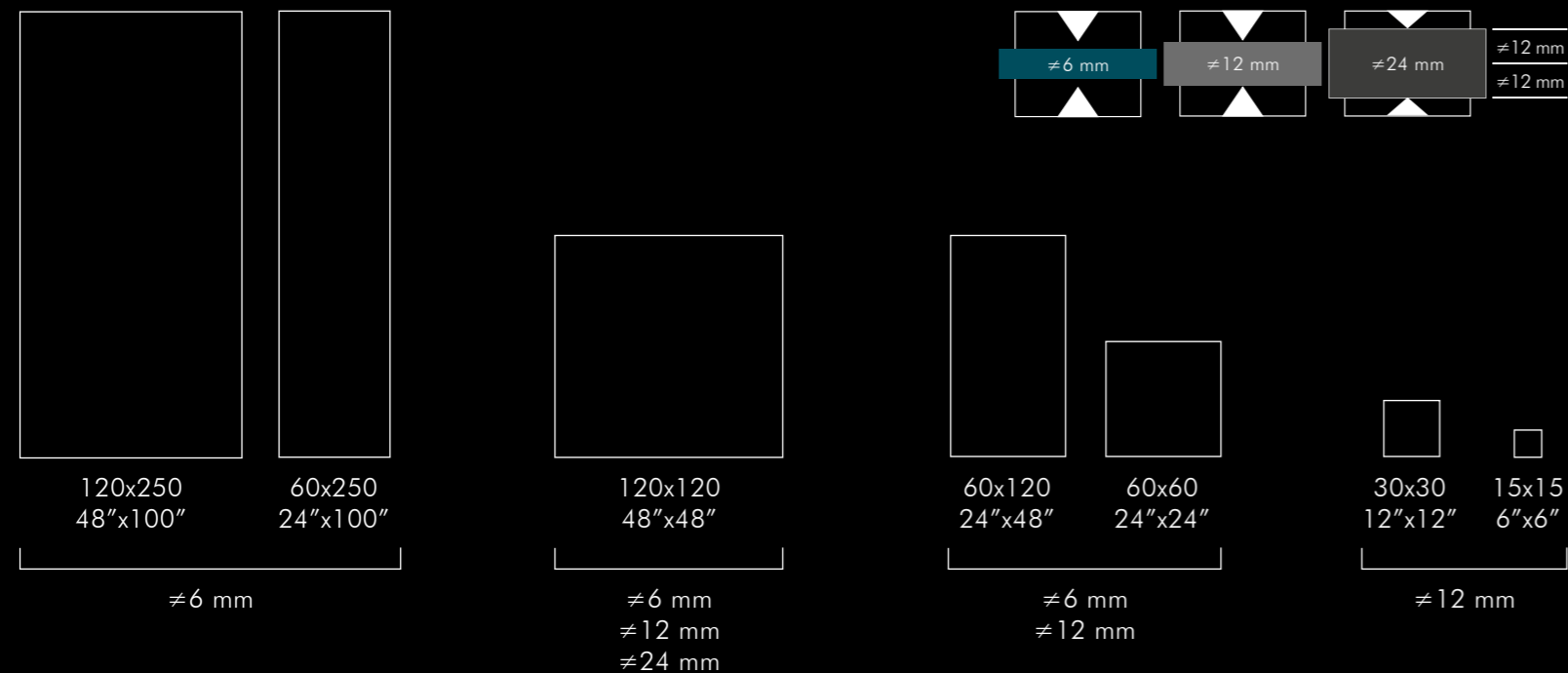

32140  
ombre  
naturelle 31

32141  
ombre  
naturelle  
moyenne

32142  
ombre  
naturelle  
claire

32013  
gris clair 31

32011  
gris 31

32010  
gris foncé 31



# Pointillé

Pointillé è una reinterpretazione della carta da parati progettata da Le Corbusier per l'azienda svizzera Salubra, la stessa che diede inizio allo studio della Polychromie Architecturale. Pointillé è fedele allo spirito del maestro e utilizza la tecnologia contemporanea per riprodurre l'effetto sorprendente del colore a parete ricercato da Le Corbusier. Era il 1931 quando Le Corbusier creò il rivestimento per pareti basato su un motivo basilico quanto estemporaneo: il "puntino" tracciato allora ad olio su una tinta unita, per evitare che l'effetto di contrasto cromatico svanisse nel tempo per effetto della luce. La combinazione dei colori è rigorosamente tratta dalla Polychromie Architecturale.

Pointille is a reinterpretation of the wallpaper designed by Le Corbusier for the Swiss company Salubra, the same one that started the study of the Polychromie Architecturale. Pointille is faithful to the spirit of the Master and uses contemporary technology to reproduce the surprising effect of the wall color sought by Le Corbusier. It was 1931 when Le Corbusier created the wall covering based on a basic and extemporaneous motif: the "dot", later traced in oil on a solid colour base. This was made to prevent the effect of chromatic contrast fading away over time due to the effect of light. The combination of the colours is strictly taken from the Polychromie Architecturale.

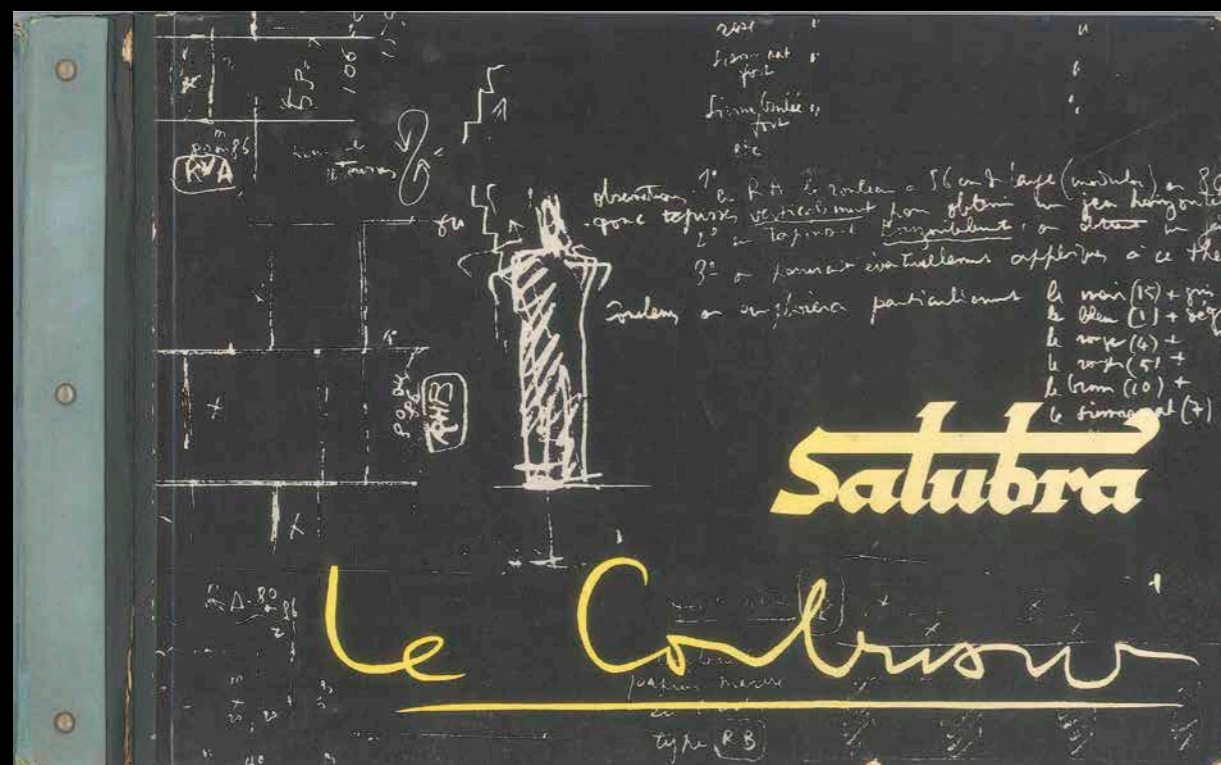

Salubra Klaviers de Couleurs 1959 ©

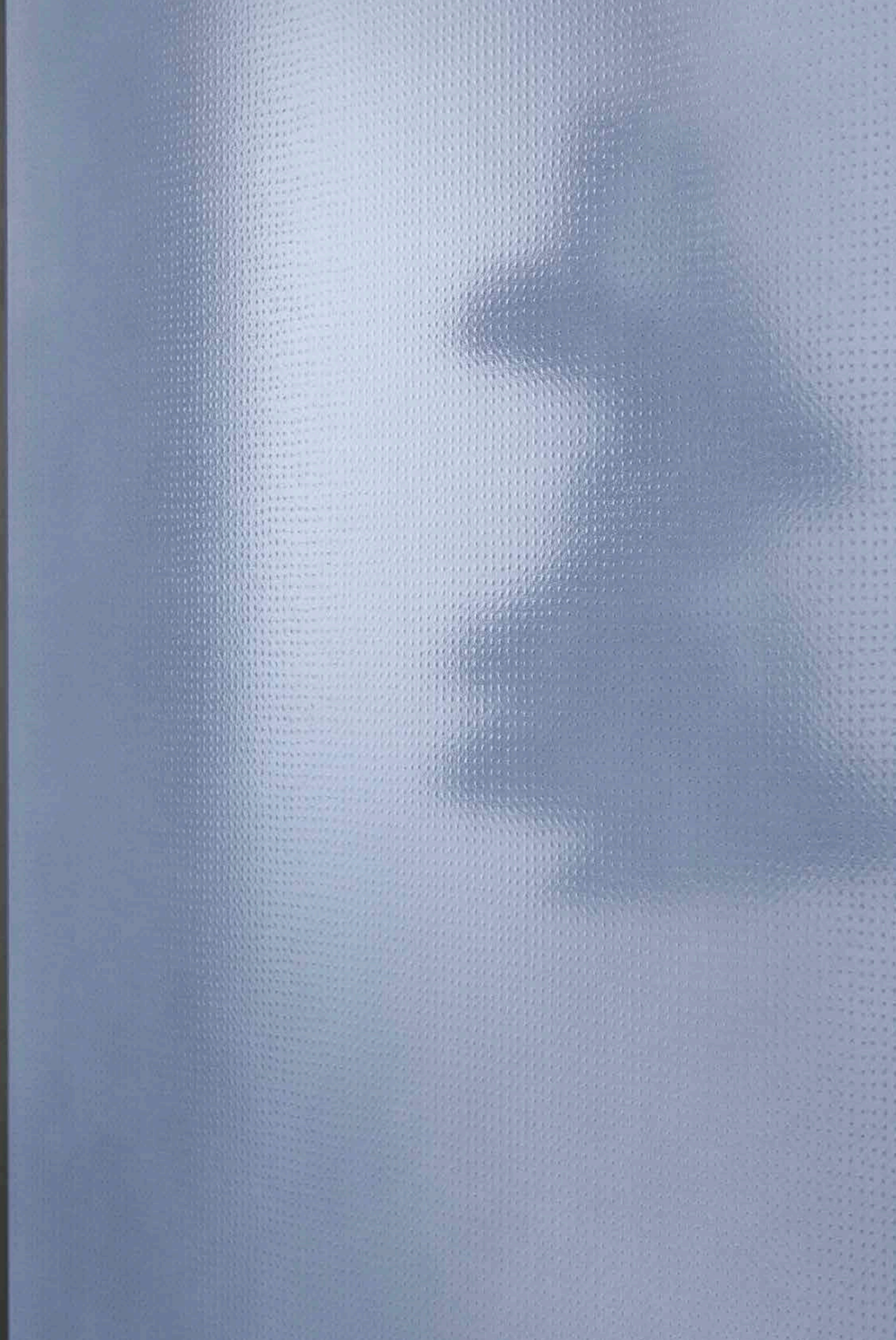

32011  
gris 31

32020  
bleu  
outrémer 31

32042  
vert anglais pâle

32142  
ombre naturelle  
claire

4320B  
blanc ivoire



# Pointillé

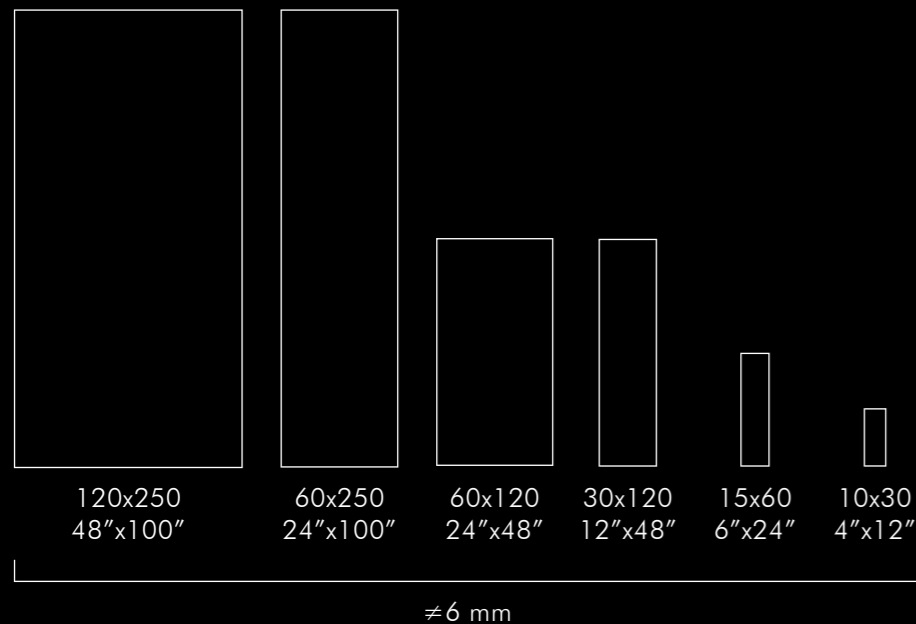

Parete | Wall  
4320B - Blanc Ivoire - Pointillé  
120x250 cm · 48"x100" ≠ 6 mm  
32140 - Ombre Naturelle 31 - Molitor  
60x250 cm · 24"x100" ≠ 6 mm





**Parete | Wall**  
Béton Gris  
120x250 cm · 48"x100" ±6 mm

4320E - Noir d'Ivoire - LCS 1  
30x120 cm · 12"x48" ±6 mm

**Pavimento | Floor**  
4320E - Noir d'Ivoire - Tokyo  
120x120 cm · 48"x48" ±6 mm



**Parete | Wall**  
Béton Blanc  
120x250 cm · 48"x100" ±6 mm

32013 - Gris Clair 31 - LCS 1  
30x120 cm · 12"x48" ±6 mm

**Pavimento | Floor**  
32013 - Gris Clair 31 - Tokyo  
120x120 cm · 48"x48" ±6 mm





**Parete | Wall**  
Blanc Béton  
120x250 cm · 48"x100" ≠6 mm

4320A - Rouge Vermillon 59 - LCS 2  
30x120 cm · 12"x48" ≠6 mm

32042 - Vert Anglais Pâle - Pointillé  
120x250 cm · 48"x100" ≠6 mm

**Pavimento | Floor**  
Blanc Béton  
60x120 cm · 24"x48" ≠12 mm



**Parete | Wall**  
32011 - Gris 31 - Pointillé  
120x250 cm · 48"x100" ≠6 mm

32010 - Gris Foncé 31 - Molitor  
60x250 cm · 24"x100" ≠6 mm

**Pavimento | Floor**  
4320E - Noir d'Ivoire - Tokyo  
120x120 cm · 48"x48" ≠6 mm





**Parete | Wall**  
 Blanc Béton  
 120x250 cm · 48"x100" ≠6 mm

4320W - Le Jaune Vif - LCS 1  
 30x120 cm · 12"x48" ≠6 mm

All colours - LCS 2  
 15x30 cm · 6"x12" ≠6 mm

**Pavimento | Floor**  
 4320W - Le Jaune Vif - Tokyo  
 120x120 cm · 48"x48" ≠6 mm



**Parete | Wall**  
 32141 - Ombre Naturelle Moyenne - Molitor  
 120x250 cm · 48"x100" ≠6 mm

32142 - Ombre Naturelle Claire - LCS 1  
 30x120 cm · 12"x48" ≠6 mm

**Pavimento | Floor**  
 32141 - Ombre Naturelle Moyenne - Molitor  
 120x250 cm · 48"x100" ≠6 mm



GIGACER offre un'inedita gamma di formati, spessori e colori naturali per progettare ogni tipo di superficie: pavimenti e rivestimenti, spazi residenziali e commerciali, indoor e outdoor, mobili, facciate ventilate e piscine. Uno strumento duttile e ricco di soluzioni per il progetto architettonico.

GIGACER ha ideato Avantime 'a new vision for architecture': un nuovo modo di vedere e interpretare un brand ceramico. Avantime è un innovativo sistema di lastre ceramiche incentrato su colori, formati, mosaici e decori. Avantime unisce in modo trasversale tutte le collezioni GIGACER regalando effetti e abbinamenti unici e originali, grazie alla filosofia di prodotto mantenuta costante e univoca nel tempo.

Nel progetto architettonico il colore è determinante per la scelta dei materiali per pavimentazioni e rivestimenti, nasce così Chromatic Vision, un'inedita gamma cromatica comprensiva di tutte le collezioni GIGACER che le ripropone secondo una logica ispirata a varie scale cromatiche e tonali.

GIGACER offers an outstanding range of formats, thicknesses and natural colours in order to design any type of surface: floors and walls, residential and commercial spaces, indoor and outdoor, furniture, ventilated facades and swimming pools. A ductile tool full of solutions for the architectural project.

Avantime is an innovative ceramic slabs' system focused on colours, formats, mosaics and decors. Avantime joins in a transversal way all the GIGACER collections, offering effects and unique and original matching thanks to the product philosophy kept constant and univocal over time.

In the architectural project, the colour is important for the choice of the materials for surface and covering; for this reason the Chromatic Vision born, an outstanding chromatic range including all the GIGACER collection, which proposes them following a logic inspired by various chromatic and tonal scales.



presents



# / CHROMATIC *vision*

Tonal  
Colour  
Gris  
Braun  
Ivory  
Blanc



# Tonal *vision*

Concrete | Made 2.0 | Concept 1

Una straordinaria gamma cromatica che dal nero si direziona verso il bianco con due diverse scale tonali: una calda e una fredda.

An extraordinary range of colours that goes from black to white with two different scales of shades: a warm one and a cool one.

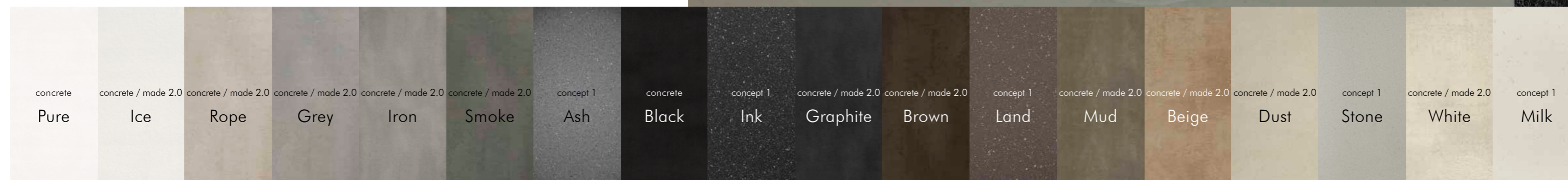
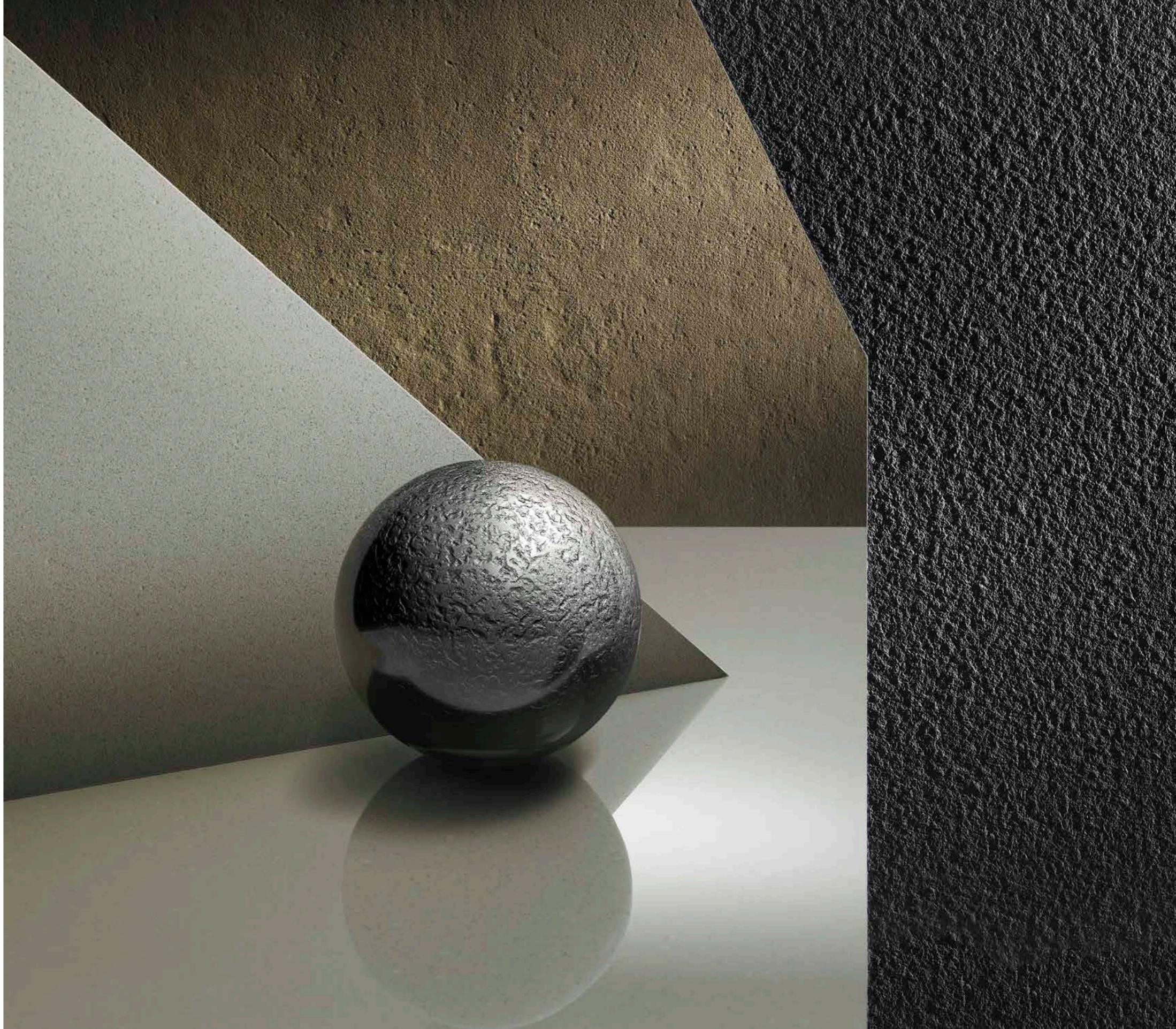





**Parete | Wall**  
Ink Platinum Texture Mat Concept 1  
120x250 cm · 48"x100" ≈6 mm

**Cubi | Cube**  
Ink Mat Concept 1  
Gigacer Service

**Pavimento | Floor**  
Milk Mat Concept 1  
120x250 cm · 48"x100" ≈6 mm





**Parete | Wall**  
Mud Concrete / Bocciardato Made 2.0  
Shades 15x15 cm · 6"x6" ≈12 mm

Mud Concrete  
120x250 cm · 48"x100" ≈6 mm

**Pavimento | Floor**  
Ice Bocciardato Made 2.0  
120x120 cm · 48"x48" ≈12 mm



**Ante cucina | Kitchen cabinets / Piano cucina | Kitchen worktop**  
Land Mat Concept 1  
Gigacer Service ≈12 mm

**Tavolo | Table**  
Land Texture Levigato Concept 1  
Gigacer Service ≈6 mm

**Pavimento | Floor**  
Milk Texture Mat Concept 1  
120x120 cm · 48"x48" ≈6 mm



# Colour *vision*

Concrete | Made 2.0 | Krea | Concept 1

Una gamma colori caratterizzata da una forte espressività e differenziazione cromatica, in particolare il rosso, il verde e l'arancione.

The colours feature strong expressiveness and contrasting shades, especially red, green and orange.

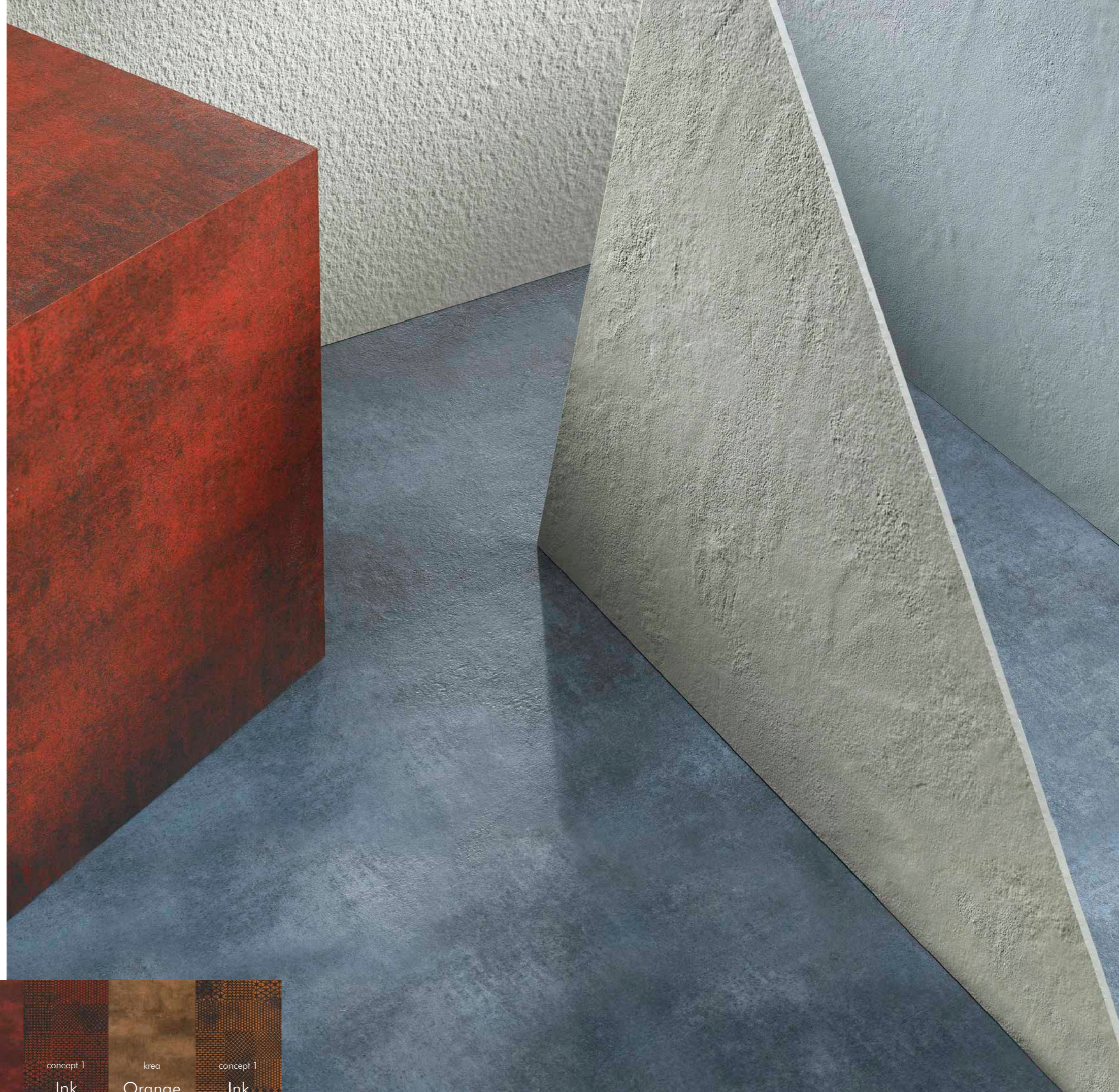





**Parete | Wall**  
Ink Platinum Texture Mat Concept 1 / Ink Texture Mat Concept 1  
120x250 cm · 48"x100" ≠6 mm

**Bancone bar | Bar counter**  
Ink Red Texture Mat Concept 1 / Ink Flame Texture Mat Concept 1  
10x10 cm · 4"x4" ≠6 mm



**Pavimento | Floor**  
Red Krea  
60x60 cm · 24"x24" ≠12 mm

Blue Krea  
30x60 cm · 12"x24" ≠12 mm





**Parete | Wall**  
Ice Concrete  
120x120 cm · 48"x48" ≠4.8 mm

**Pavimento | Floor**  
Ice Concrete / Blue Krea  
Diamond 18x31 cm · 7"x12" ≠4.8 mm

Ice Concrete / Blue Krea  
10x60 cm · 4"x24" ≠4.8 mm

Ice Concrete  
20x120 cm · 8"x48" ≠4.8 mm



**Parete | Wall**  
Vetiver Material Argilla  
120x120 cm · 48"x48" ≠6 mm

**Pavimento | Floor**  
Ice Concrete  
120x250 cm · 48"x100" ≠6 mm



# Gris *vision*

Concrete | Made 2.0 | Krea | Argilla | Concept 1

Undici diverse tonalità di grigio in prevalenza fredde.

Eleven different shades of cool grey.

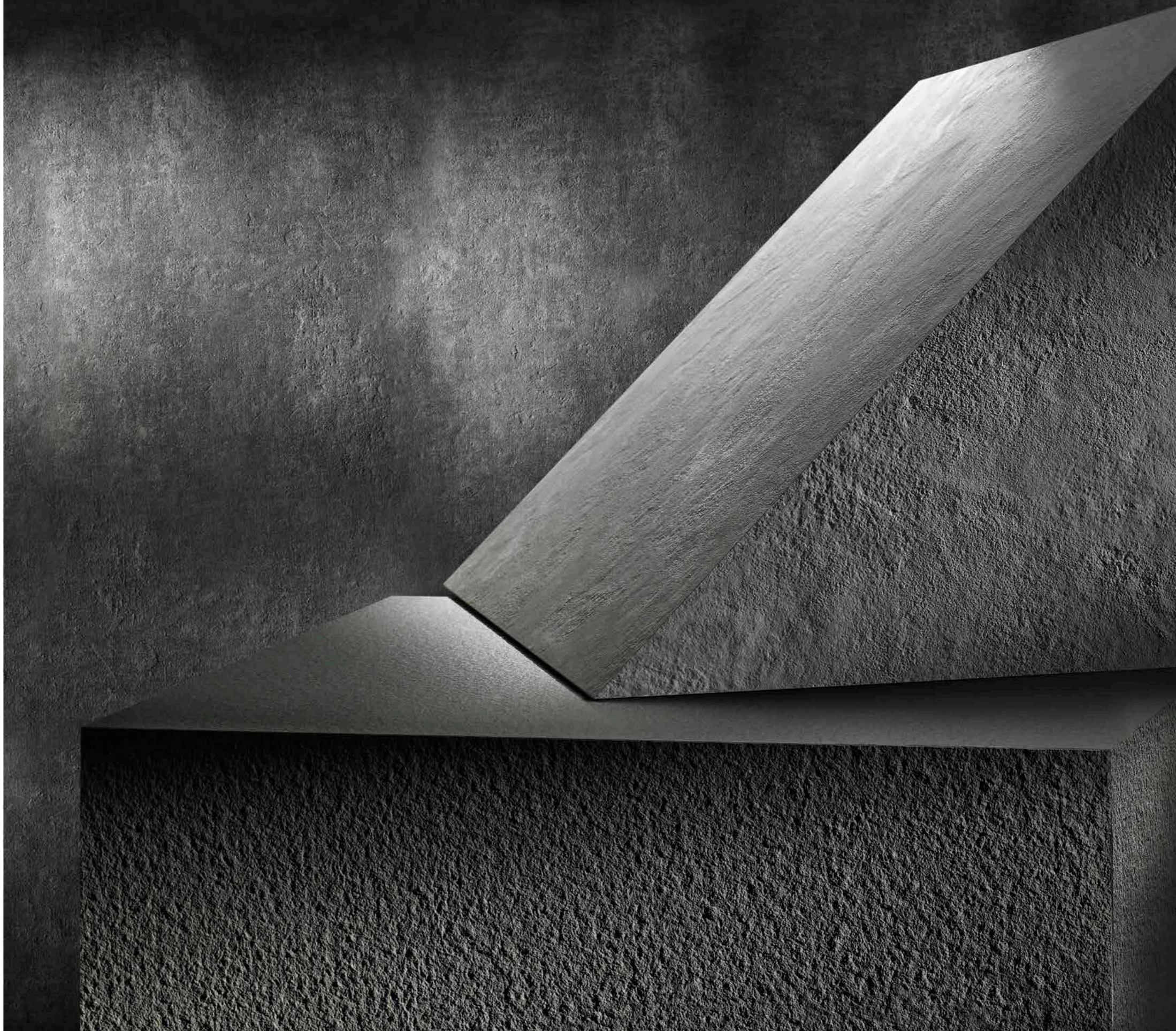





**Pavimento | Floor**  
Smoke Blend Concrete / Bocciardato Made 2.0  
5/10/15x60 cm · 2"/4"/6"x24" ≠12 mm



**Parete | Wall**  
Rope / Smoke Concrete  
60x250 cm · 24"x100" ≠6 mm

**Pavimento | Floor**  
Ice Concrete  
120x120 cm · 48"x48" ≠12 mm





**Pavimento | Floor**

Ice Concrete / Graphite Concrete / Snow Krea  
Diamond 18x31 cm · 7"x12" ≈4.8 mm

Ice Concrete / Graphite Concrete / Snow Krea  
9x30 cm · 3 1/2"x12" ⚙️ Gigacer Service ≈4.8 mm



**Parete | Wall**

Stone Texture Levigato Concept 1  
120x250 cm · 48"x100" ≈6 mm

**Ante cucina | Kitchen cabinets**

Ash Mat Concept 1  
⚙️ Gigacer Service ≈6 mm



# Braun *vision*

Concrete | Made 2.0 | Krea | Argilla | Concept 1

Scala colore caratterizzata da una cromia armonica composta da tinte naturali in tonalità calde.

A colour scale of harmonic and natural warm shades composed of natural, warm hues.

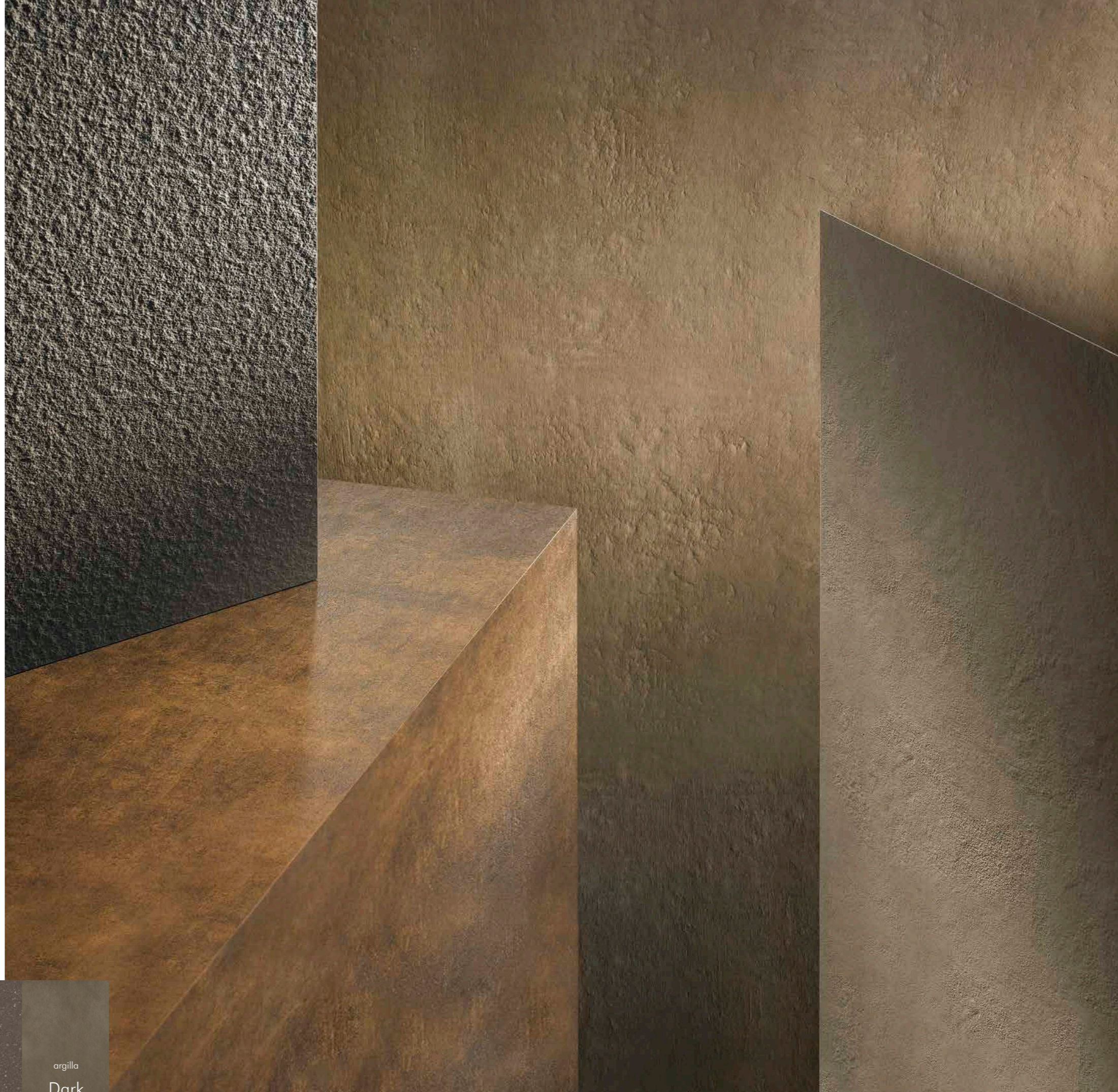





**Parete | Wall**  
Brown / Mud Concrete  
60x120 cm · 24"x48" ≈4.8 mm

**Vasca | Bathtub**  
Brown Concrete  
Gigacer Service

**Pavimento | Floor**  
Brown Concrete  
60x60 cm · 24"x24" ≈12 mm



**Parete | Wall**  
Dark Argilla Material  
Mosaic 3x6 / 30x30 cm · 12"x12" ≈6 mm

**Pavimento | Floor**  
Fog Argilla Material  
120x120 cm · 48"x48" ≈6 mm





**Parete | Wall**  
Orange Krea  
120x120 cm · 48"x48" ≈ 4.8 mm

Orange Krea  
Stripes Mosaic 15x120 cm · 6"x48" ≈ 4.8 mm

**Pavimento | Floor**  
Krea Orange / Mud Concrete / Brown Concrete  
Diamond 18x31 · 7"x12" ≈ 4.8 mm

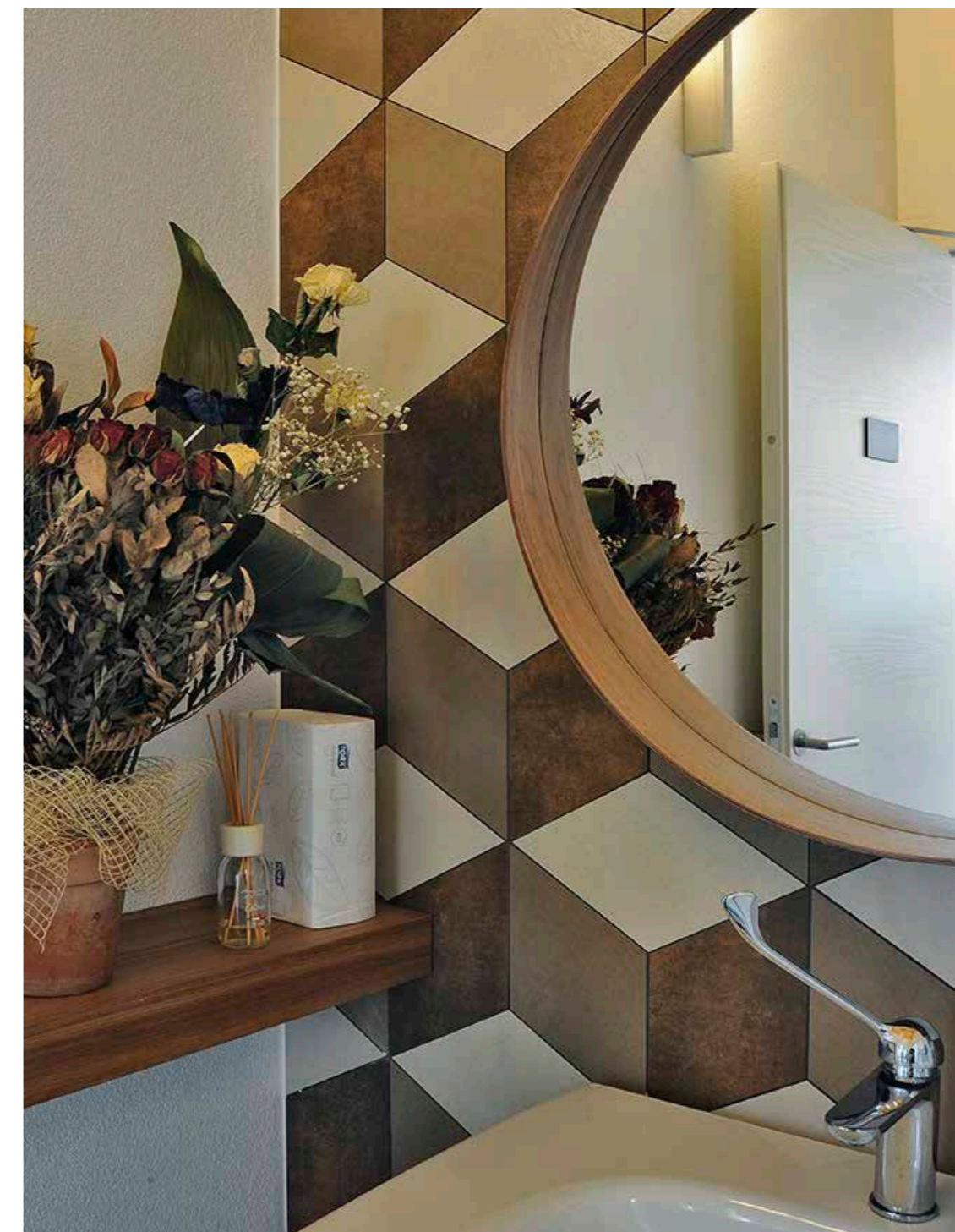

**Parete | Wall**  
Krea Orange / Mud Concrete / Brown Concrete  
Diamond 18x31 · 7"x12" ≈ 4.8 mm



# Ivory *vision*

Concrete | Made 2.0 | Argilla | Light | Concept 1

Bianco puro, avorio, argille chiare sono i colori in assoluto più utilizzati in architettura; di facile abbinamento, eleganti e raffinati.

Pure white, ivory and light clays are the most used colours in architecture; easy to combine, elegant and refined.







**Parete | Wall**  
Ice / White / Rope Concrete  
Diamond 18x31 · 7"x12" ≈4.8 mm

Ice Concrete  
15x60 cm · 6"x24" / 10x60 cm · 4"x24"  ≈4.8 mm

**Pavimento | Floor**  
Rope Concrete  
60x250 cm · 24"x100" ≈4.8 mm

White Concrete  
Stripe Mosaic 1.5x120 · 15x120 cm · 48"x6" ≈4.8 mm





**Parete | Wall**  
Ice Levigato Made 2.0  
120x120 cm · 48"x48" ≈12 mm

**Pavimento | Floor**  
Mud Blend Concrete  
5/10/15x60 cm · 2"/4"/6"x24" ≈4.8 mm



**Pavimento | Floor**  
Ice Concrete  
120x120 cm · 48"x48" ≈12 mm



# Blanc *vision*

Concrete | Made 2.0 | Light

Un inedito e raffinato insieme di bianchi il cui unico tono colore si sviluppa in sei diverse superfici, in vari formati e spessori. Sono la luce e la texture a modulare la cromia e la percezione del bianco.

An original and elegant set of whites, whose unique shade of colour extends over six different surfaces in various shapes and thicknesses. It's light and texture that change the perceived shade of white.







**Parete | Wall**  
Ice Concrete  
120x250 cm · 48"x100" ±6 mm

**Pavimento | Floor**  
Gesso / Rigato / Scolpito / Roccià / Crespo Light  
120x120 cm · 48"x48" ±6 mm

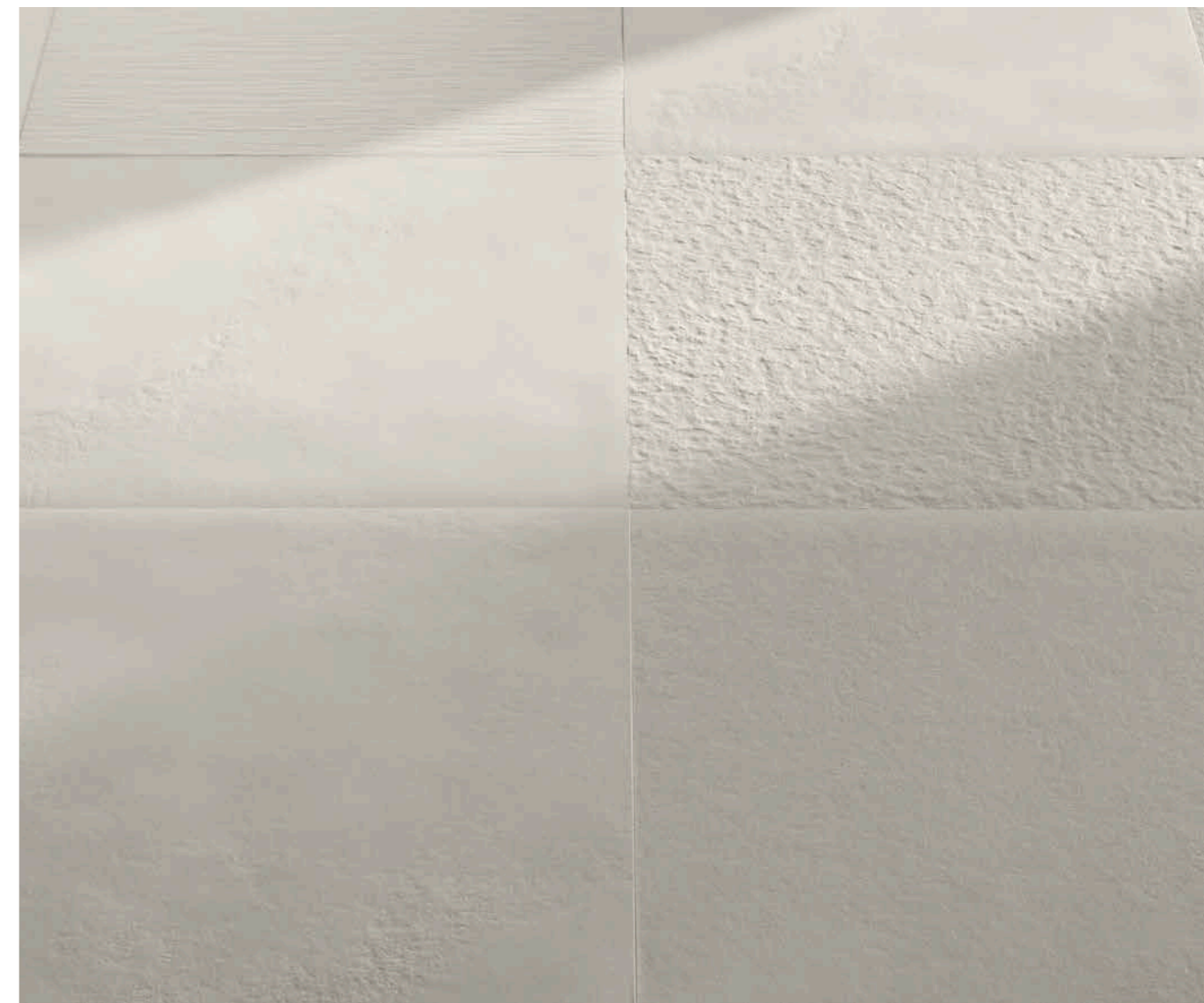





**Parete | Wall**  
Graphite Concrete  
120x250 cm · 48"x100" ±6 mm

Gesso / Rigato / Scolpito / Roccia / Crespo Light  
Blend 20x20 cm · 8"x8" ±6 mm

**Pavimento | Floor**  
Graphite Concrete  
120x120 cm · 48"x48" ±12 mm





Per la prima volta la gamma Gigacer si arricchisce di pura decorazione: un vero e proprio accento su Avantime - Chromatic Vision. La proposta di lastre 120x250 cm e dei loro tagli permette sia l'utilizzo a campo pieno della decorazione, sia l'accostamento di inserti ai colori contenuti nella visioni cromatiche di Avantime - Chromatic Vision.

Gigacer introduces pure decoration for the first time: a real accent on Avantime - Chromatic Vision. The proposal of 120x250 cm slabs and their cuts allows both the full-field use of the decoration and the combination of inserts with the colors contained in the Chromatic Vision of Avantime.



presents



# / An accent on Avantime

Déco & Chromatic vision

Light & Chromatic vision



# Déco

& Chromatic Vision

Déco si affida alle linee curve e ai dettagli floreali di un paesaggio immaginario, lasciando prevalere l'aspetto vetroso e traslucido ad effetto ceramico di una collezione integrata con i colori basici e neutri della gamma cromatica di Avantime Chromatic Vision.

Déco relies on the curved lines and floral details of an imaginary landscape, allowing the glass-like and translucent ceramic effect prevail in a collection that is integrated with the basic and neutral colours of Avantime Chromatic Vision.







articoli in foto | photo suggestions



articoli in foto | photo suggestions





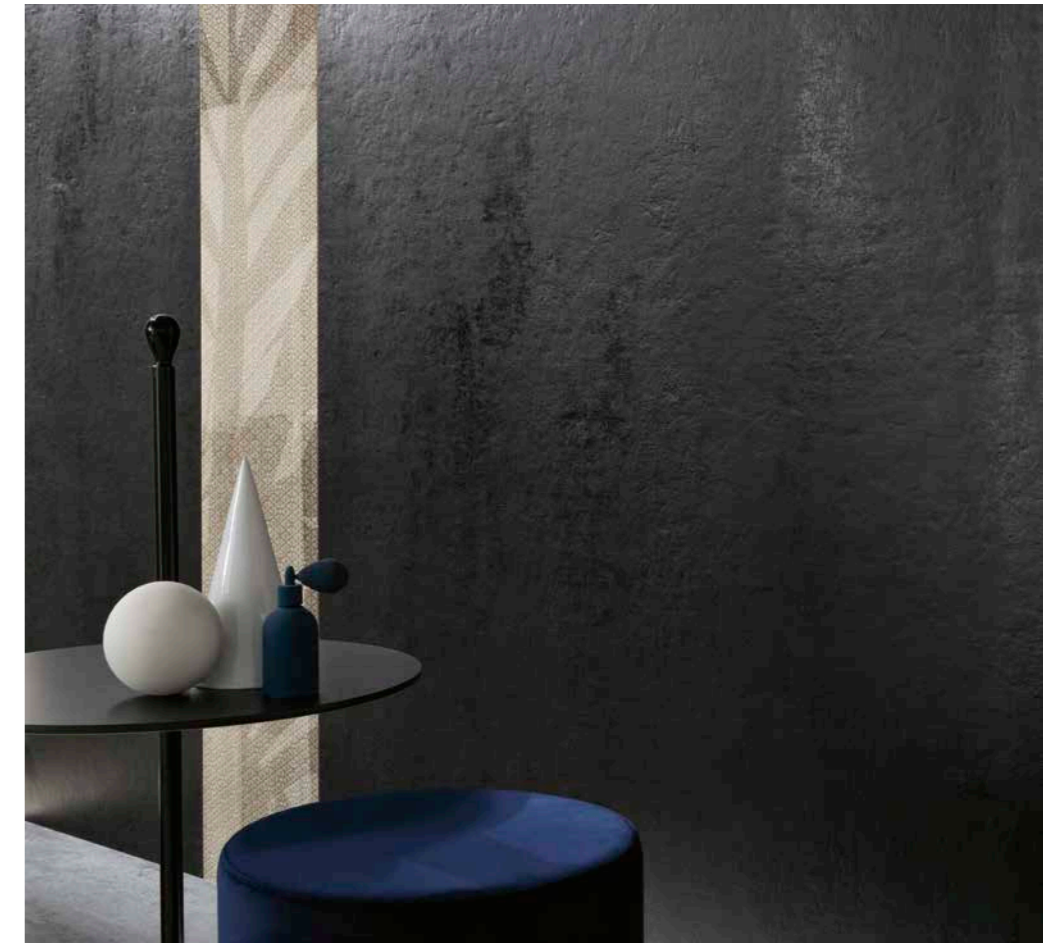

articoli in foto | photo suggestions





# Light 250

& Chromatic Vision

La luce è la nostra ispirazione. La raffinata tessitura del cotone, le sottili trasparenze e il morbido bianco opaco si cristallizzano nella parete.

Lightness is our inspiration. The refined cotton weaving, the subtle transparencies and the soft mat white crystallize in the wall.

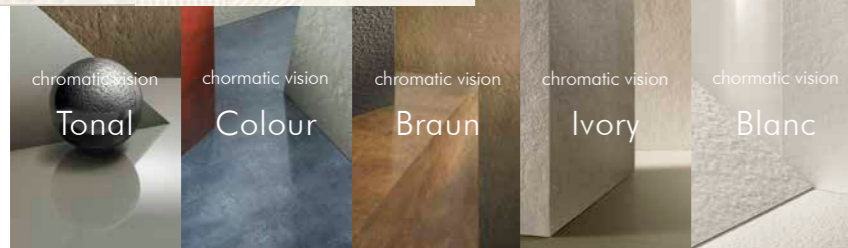
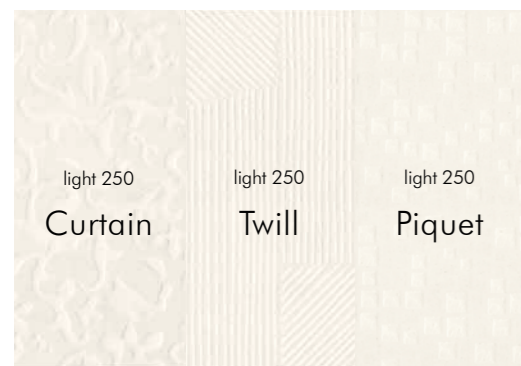





articoli in foto | photo suggestions



articoli in foto | photo suggestions







articoli in foto | photo suggestions



articoli in foto | photo suggestions



PlayOne è un articolato sistema di piccoli formati della gamma cromatica Gigacer, tipicamente declinata in grandi superfici. È il gioco degli abbinamenti tra forme e colori. Lo spessore sottile permette sempre l'abbinamento con la grande lastra, invitando alla combinazione del grande con il piccolo, della superficie continua con il pattern decorativo. Il basso spessore di Gigacer è ideale sia per i pavimenti che i rivestimenti, includendo al suo interno tutte le superfici orizzontali e verticali. PlayOne è un invito alla personalizzazione degli ambienti, il modo per trasformare uno spazio abitativo nel nostro spazio.

PlayOne is an articulated system of small sizes available in the Gigacer chromatic range, typically declined in big surfaces. It is the game of combinations of shapes and colours. The thin thickness always allows the combination with the big slabs, creating a combination within the big and the small with the continuous surface of the decorative pattern. The low thickness of Gigacer is suitable both for floors and coverings, including on the inside all the horizontal and vertical surfaces. PlayOne is an invite to customize the spaces, in order to transform a living space in our space.

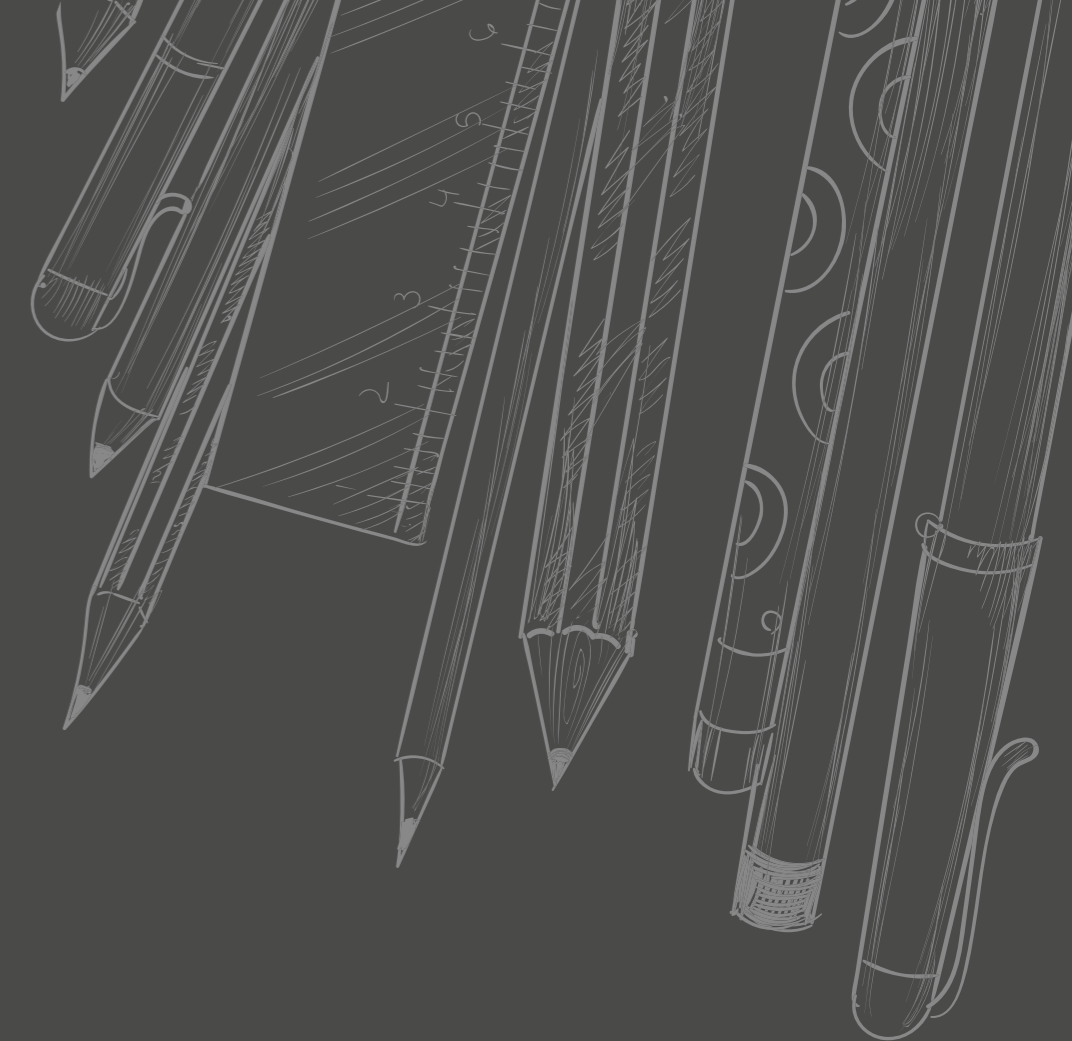

presents

**PlayOne**  
Small Tiles More Design

/ **PlayOne**

Shapes

Mosaics

Brick Bar



# Shapes

La ricca scelta di piccole forme offre una chiara sintesi di tradizione e contemporaneità. Shapes al suo interno include vari poligoni come rombi, esagoni, pentagoni tutti modulari tra di loro. Le diverse composizioni sono un perfetto connubio tra la ricerca della decorazione e uno stile minimalista dall'aspetto materico.

The rich choice of small shapes offers a clear synthesis of tradition and contemporaneity. Inside, Shapes includes a variety of polygons such as rhombuses, hexagons, pentagons, all modular between them. The different compositions are a perfect combination between the research of the decoration and a minimalist style with a material aspect.

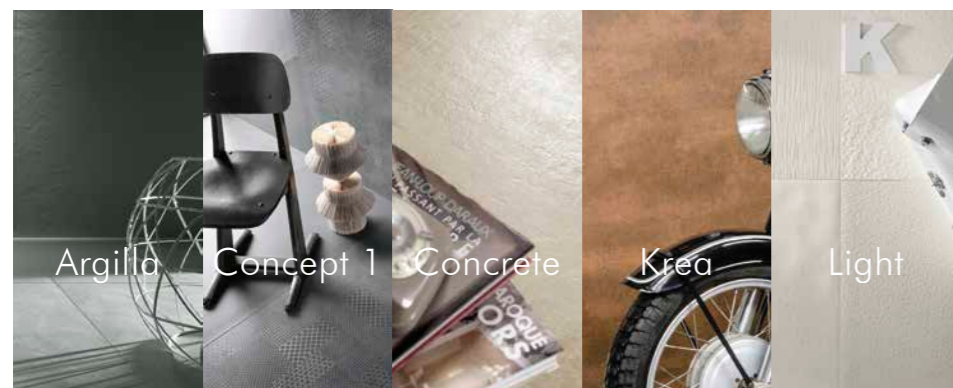

Argilla

Concept 1

Concrete

Krea

Light



# PlayOne shapes



button	octagon	small	brick	plate	small pentagon	small hexagon	large hexagon	triangle	diamond
3x3	30x30	9x9	9x18	9x30	17x10	18x16	37x32	18x16	18x31
1 1/4"x1 1/4"	12"x12"	3 1/2"x3 1/2"	3 1/2"x7"	3 1/2"x12"	7"x4"	7"x6"	14 1/2"x12 1/2"	7"x6"	7"x12"

≠4.8 mm / ≠6 mm - PlayOne Shapes



formati rettificati / rectified sizes

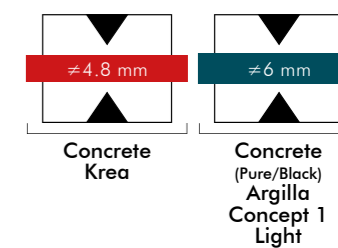
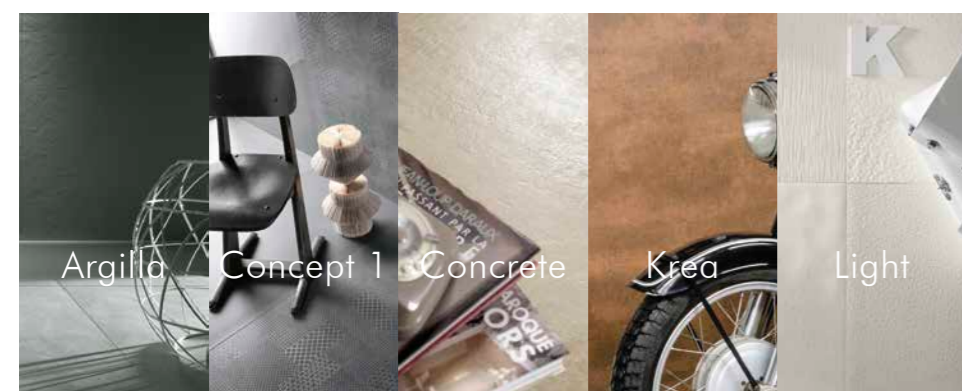
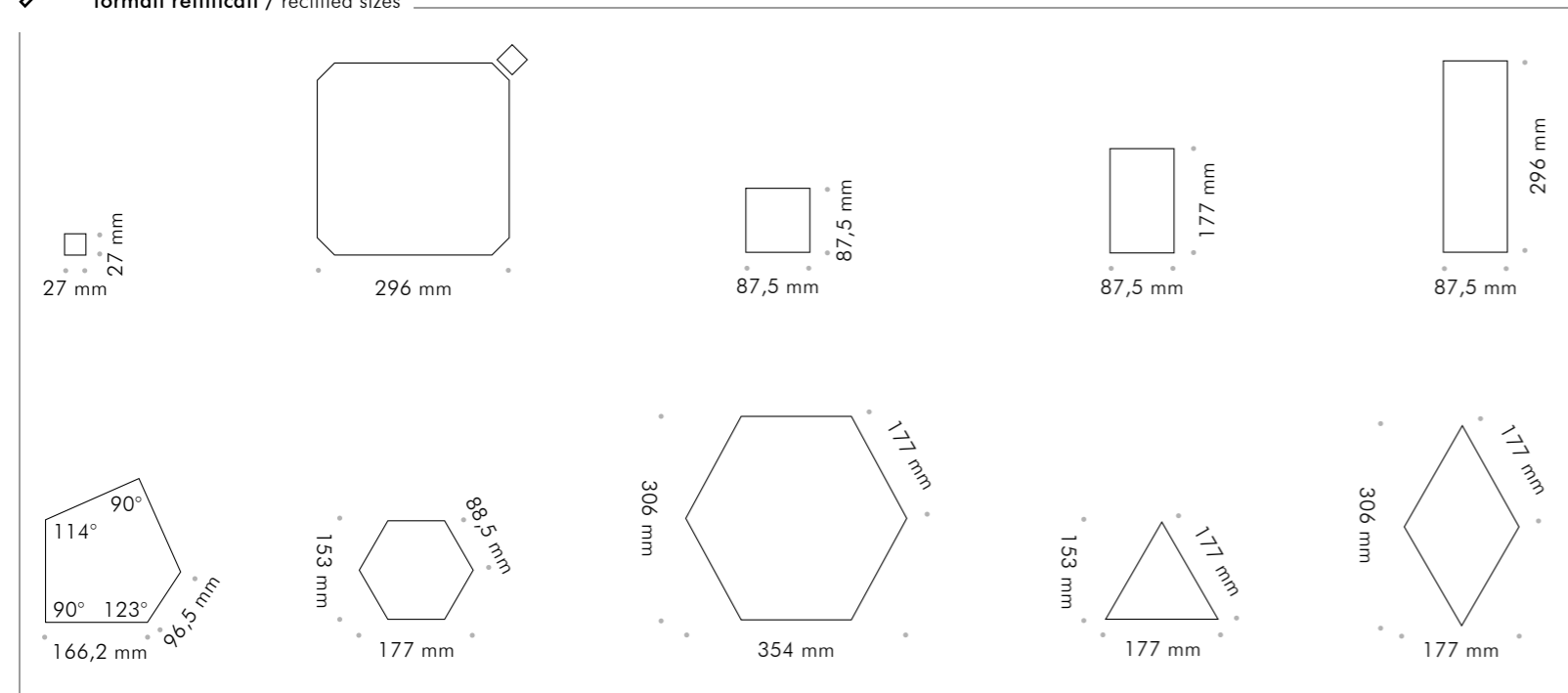





**Parete | Wall**  
 Marine Material Argilla / Bianca Material Argilla  
 Small Pentagon 17x10 cm · 7"x4" ≈ 6 mm

**Top | Piano**  
 White Concrete  
 Gigacer Service ≈ 12 mm

**Pavimento | Floor**  
 Marine Quartz Argilla  
 60x60 cm · 24"x24" ≈ 12 mm



**Pavimento | Floor**  
 Snow / Green Krea  
 30x30 cm · 12"x12" Gigacer Service ≈ 4.8 mm

Red Krea  
 Diamond 18x31 cm · 7"x12" ≈ 4.8 mm

Silver Krea  
 Plate 9x30 cm · 3 1/2"x12" ≈ 4.8 mm

Silver Krea  
 Brick 9x18 cm · 3 1/2"x7" ≈ 4.8 mm





**Pavimento | Floor**

Ice Concrete  
Octagon 30x30 cm · 12"x12" ±4.8 mm

Graphite / Ice Concrete  
30x30 cm · 12"x12" ±4.8 mm

Graphite Concrete  
Button 3x3 cm · 1 1/4"x1 1/4" ±4.8 mm



**Parete | Wall**  
Ground / Orange Krea  
Large Hexagon 36x31 cm · 14"x12" ±4.8 mm

**Pavimento | Floor**  
Ground Krea  
120x120 cm · 48"x48" ±4.8 mm

Mosaic 1.5x1.5 Orange Krea  
30x30 cm · 12"x12" ±4.8 mm



# Mosaics

Il formato mosaico di Gigacer riassume la forte passione dell'azienda per il dettaglio. Ogni colore della gamma Gigacer ha al suo interno il formato mosaico che permette di completare e arricchire di pregiate finiture gli ambienti, offrire soluzioni per superfici curve o sottolineare determinati particolari di progetto.

Le trame del mosaico in tutte le tonalità sono l'accento al minimalismo classico delle collezioni Gigacer e permettono di offrire una palette cromatica unica nel gres porcellanato.

The mosaic size of Gigacer resumes the strong passion of the company for the detail. Every Gigacer's colour range has its mosaic sizes which allows to complete and enrich spaces with precious finishes, offering solutions for curved surfaces or emphasize certain projects. The textures of the mosaic in all the shades are the accent to the classic minimalism of the Gigacer collections and allow You to offer a unique chromatic palette in porcelain stoneware.

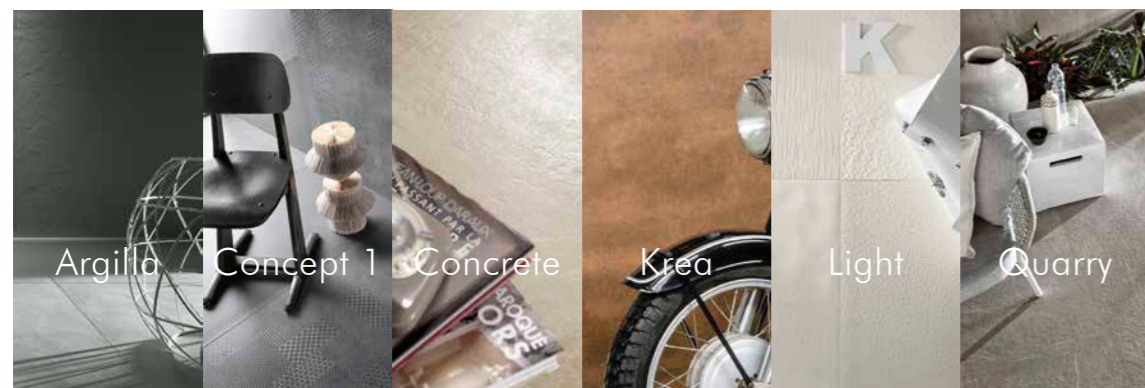



# PlayOne mosaics



mosaic 0.7x0.7	mosaic 1.5x1.5	mix mosaic 1.5x1.5	action mosaic 4.4x5.2	stripes mosaic 1.5x60	stripes mosaic 1.5x120	stripes mosaic 1.5x120	mix mosaic 3x3
30x30 12"x12"	30x30 12"x12"	30x30 12"x12"	30x30 12"x12"	30x60 12"x24"	15x120 6"x48"	15x120 6"x48"	30x30 12"x12"

≠4.8 mm / ≠6 mm - PlayOne Mosaics

≠4.8 mm  
≠6 mm  
≠12 mm  
PlayOne  
Mosaics

wall mosaic	wall mosaic mix A	wall mosaic mix B	mix mosaic 0.7x0.7	mosaic 3x6	mix mosaic 3x6	mix 3d mosaic	trail mosaic 10x2
30x30 12"x12"	30x30 12"x12"	30x30 12"x12"	30x30 12"x12"	30x30 12"x12"	30x30 12"x12"	30x17 12"x6 1/2"	30x30 12"x12"

≠4.8 mm  
≠6 mm  
PlayOne  
Mosaics

≠4.8 mm - PlayOne Mosaics

≠6 mm - PlayOne Mosaics

≠12 mm  
PlayOne  
Mosaics

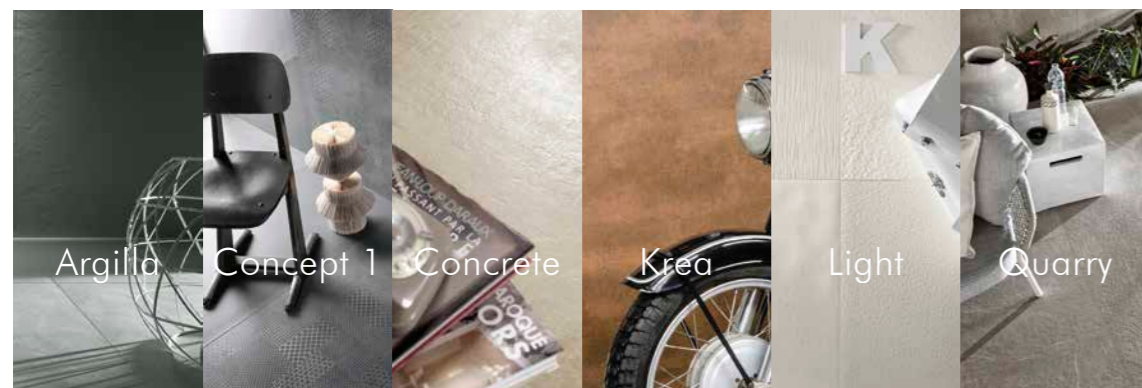

Mosaici forniti su rete  
Mosaics are mesh-mounted

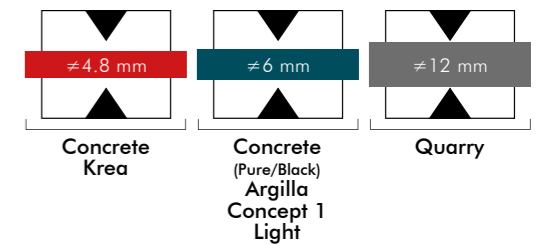





**Parete | Wall**  
Veniver Material Argilla  
60x120 cm - 24"x48" ≠6 mm  
Vefiver Material Argilla  
Stripes Mosaic 1.5x120 cm - 15x120 cm - 6"x48" ≠6 mm



**Parete | Wall**  
Dark Material Argilla  
Mosaic 3x6 30x30 cm · 12"x12" ≠6 mm

**Pavimento | Floor**  
Fog Material Argilla  
120x120 cm · 48"x48" ≠6 mm

**Bancone | Counter**  
Graphite Concrete  
Gigacer Service ≠12 mm



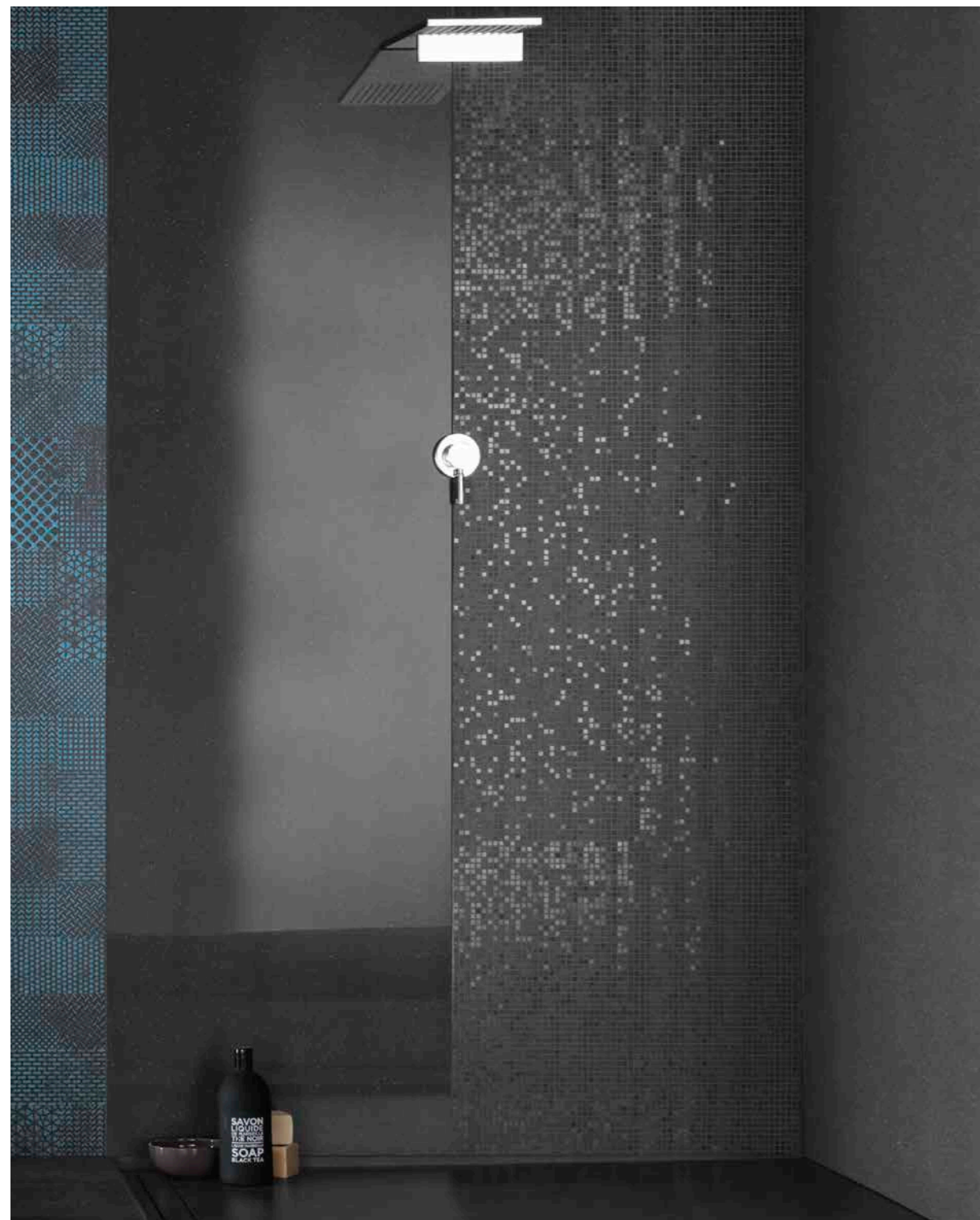

**Parete | Wall**  
Ink Levigato / Ink Turquoise Texture Mat Concept 1  
60x250 cm · 24"x100" ≈6 mm

Ink Mat / Levigato Concept 1  
Mosaic 0.7x0.7 30x30 cm · 12"x12" ≈6 mm

**Pavimento | Floor**  
Ink Bocciardato Concept 1  
120x120 cm · 48"x48" ≈12 mm

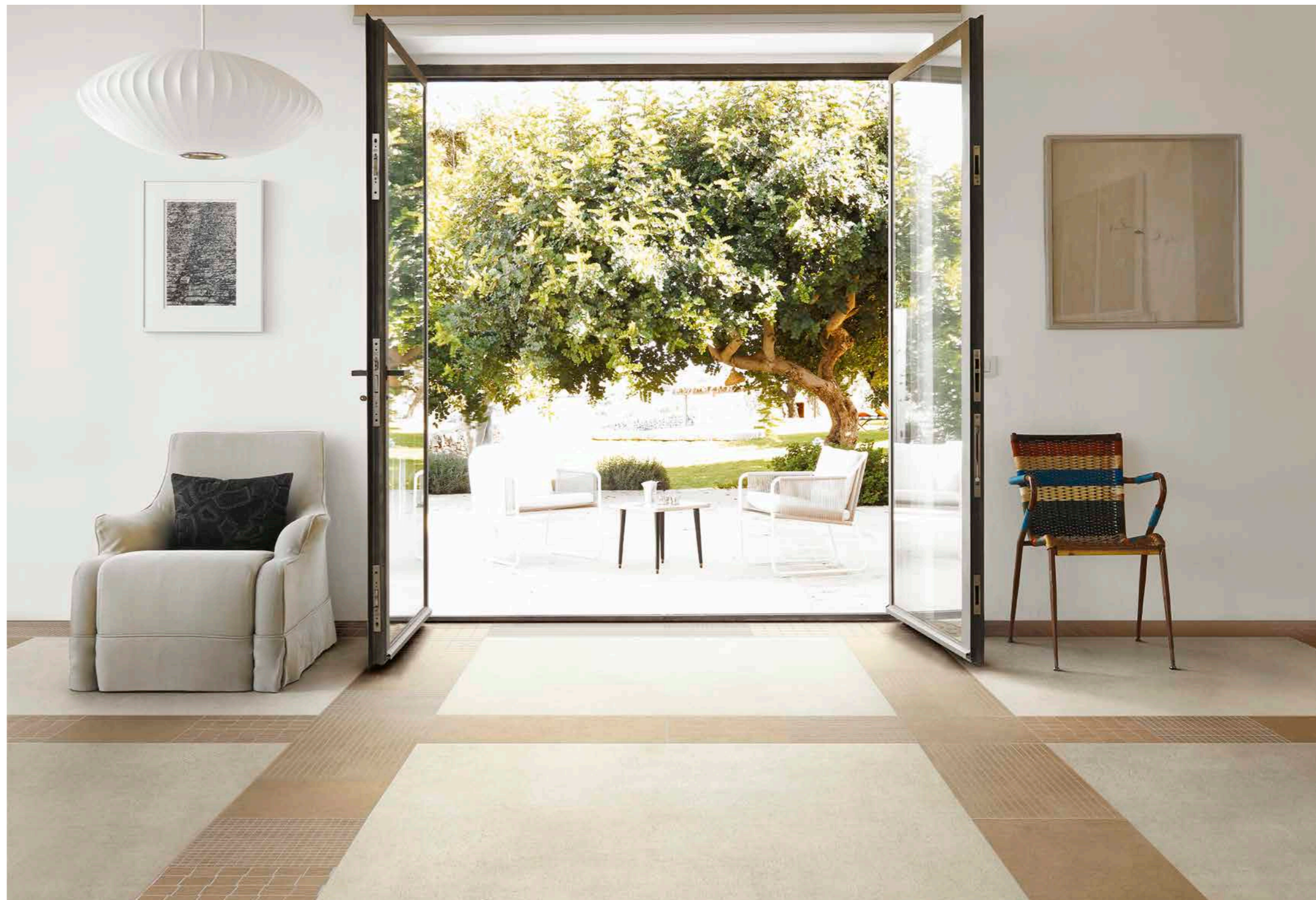

**Pavimento | Floor**  
Rope / White Concrete  
120x120 cm · 48"x48" ≈4.8 mm

Beige Concrete  
30x60 cm · 12"x24" / 30x30 cm · 12"x12" ≈4.8 mm

Beige Concrete  
Stripes Mosaic 30x60 cm · 12"x24" / Mosaic 1.5x1.5 30x30 cm · 12"x12"  
Action Mosaic 30x30 cm · 12"x12" ≈4.8 mm



# Brick Bar

Una forte connotazione minimal con un aspetto a tratti vintage. Il Brick Bar garantisce l'effetto industrial richiamando il classico mattoncino dei loft newyorkesi ma presenta un'importante e fondamentale facilità di posa. La struttura a listello 7,5x60 cm è divisa in quattro parti uguali tramite una pre-incisione studiata per diventare fuga dopo la stuccatura, formando in parete ma anche a pavimento elementi dello spazio metropolitani o domestici dal gusto ritrovato, a seconda delle interpretazioni stilistiche. Brick Bar è disponibile in tutti i colori Gigacer presenti con lo spessore 12 mm.

A strong minimal connotation with a vintage look. The Brick Bar guarantees the industrial effect recalling the classic brick of the New York lofts, but it has an important and fundamental ease of installation. The 7.5x60cm strip structure is divided into four equal parts by means of a pre-incision designed to become a joint after grouting, forming metropolitan or domestic elements of space with a rediscovered taste on the wall but also on the floor, depending on the stylistic interpretations. Brick Bar is available in all Gigacer colours present with a 12mm thickness.

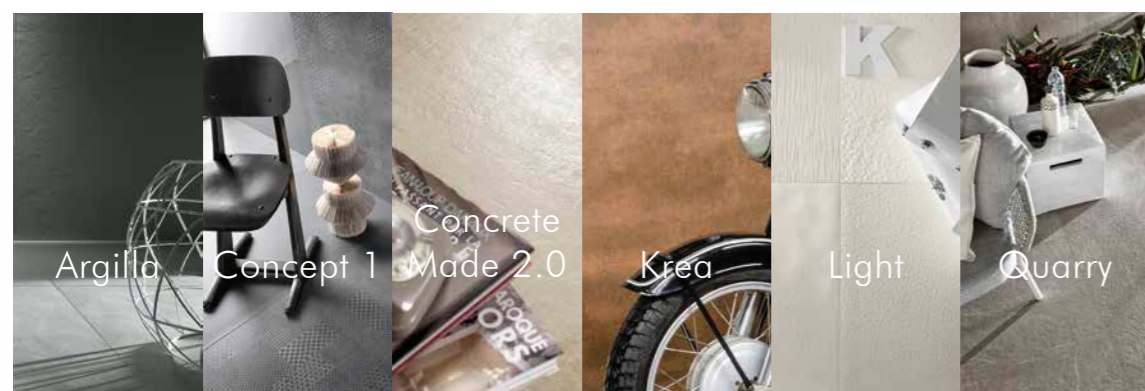
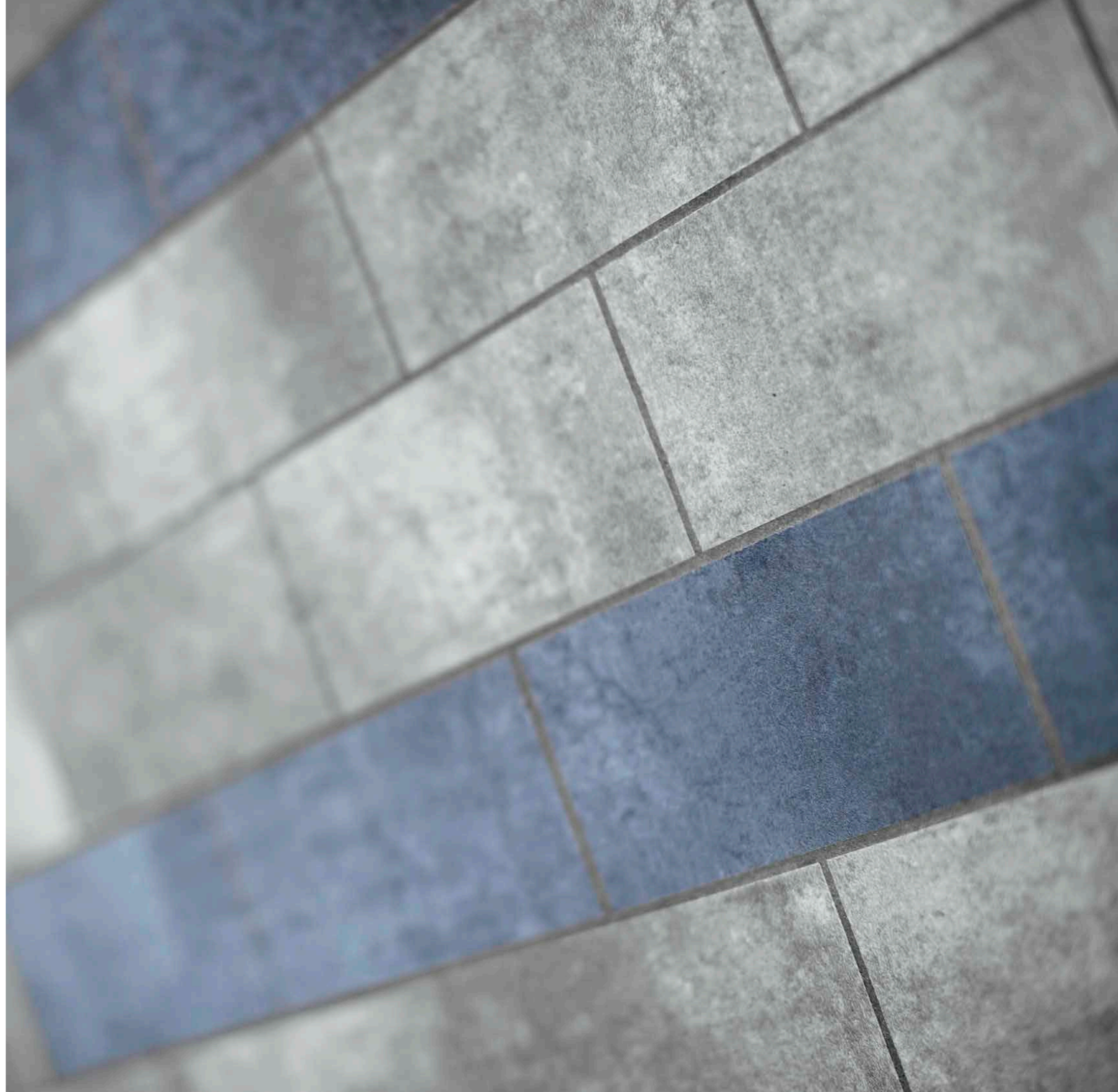



# PlayOne brick bar



brick bar

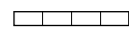

7,5x60  
3"x24"

± 12 mm - PlayOne Brick Bar

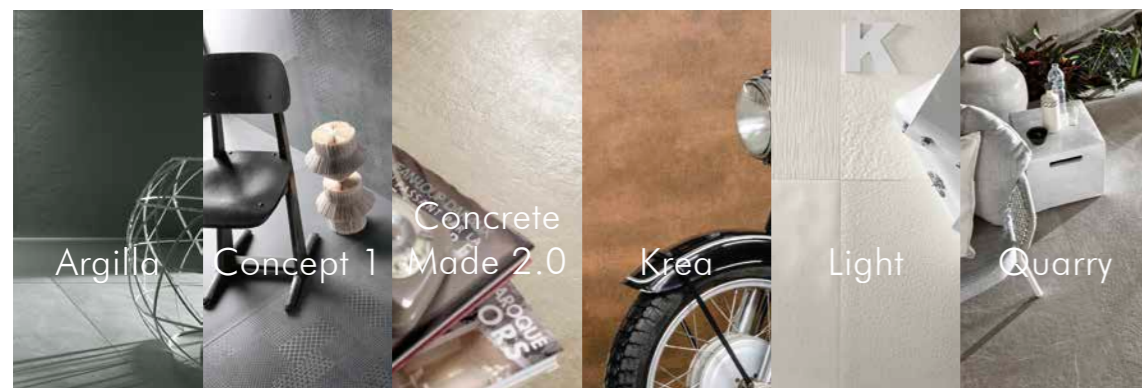
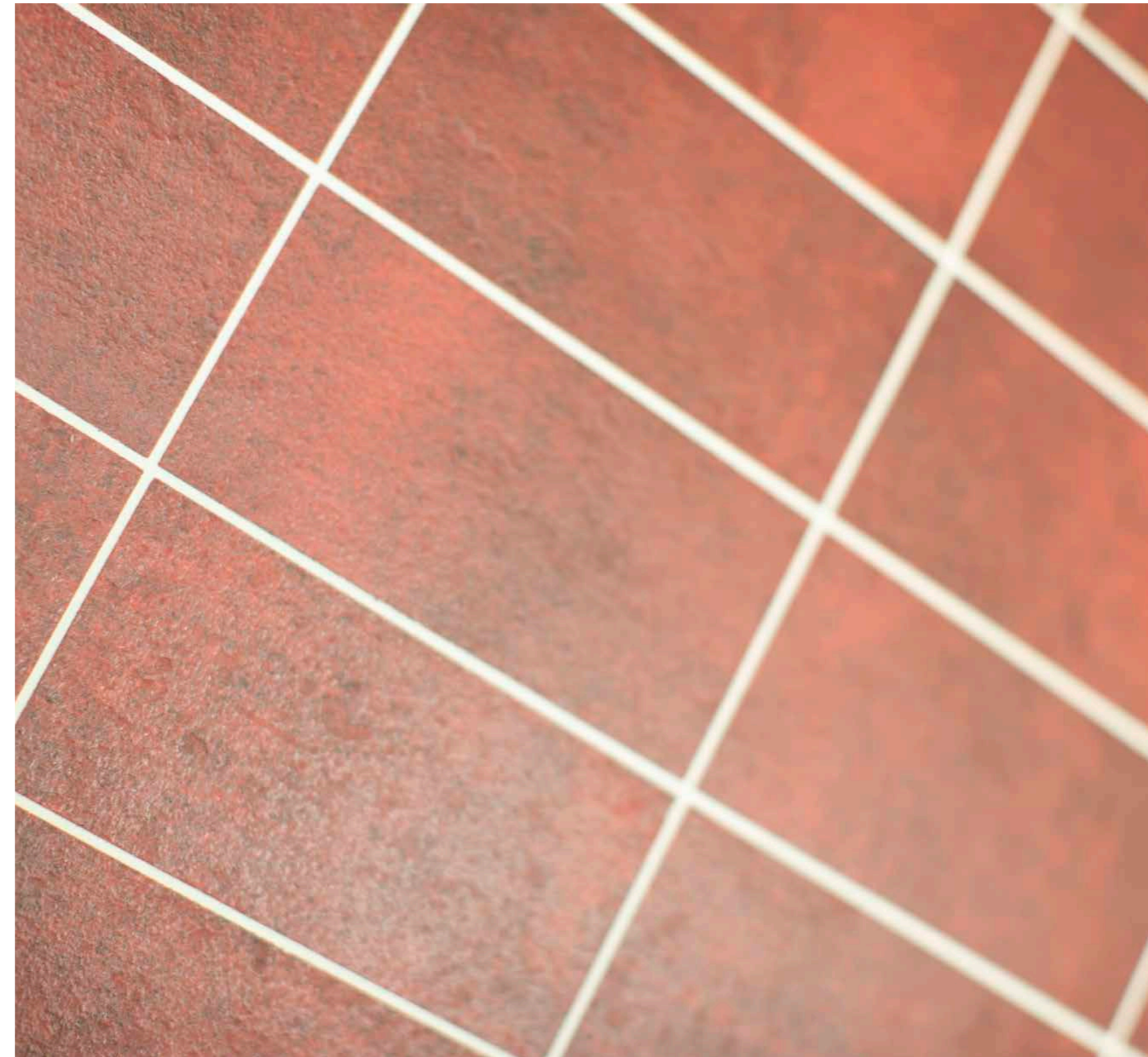

Argilla

Concept 1

Concrete  
Made 2.0

Krea

Light

Quarry

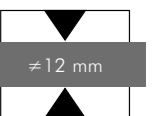





**Parete | Wall**  
Green / Snow Green Krea  
Brick Bar 7,5x60 cm · 3"x24" ≠12 mm

**Top cucina | Kitchen worktop**  
Graphite Concrete  
Gigacer Service

**Pavimento | Floor**  
Ground Krea  
120x120 cm · 48"x48" ≠12 mm





Gigacer offre al professionista un'inedita gamma cromatica, che si abbina in modo trasversale all'importante sistema di formati, spessori e superfici pensati per ogni utilizzo in architettura:

- / Spazi residenziali e commerciali
- / Pavimenti e rivestimenti
- / Piani lavoro piena massa
- / Scale e pezzi speciali
- / Facciate ventilate
- / Pavimenti carrabili
- / Piscine & Spa

Gigacer offers the professional an unprecedented colour range that can be combined in multiple ways with the important system of shapes, thicknesses and surfaces designed for every use in architecture:

- / Residential and commercial spaces
- / Flooring and cladding
- / Through body worktops
- / Stairs and special pieces
- / Ventilated façades
- / Vehicle accessible flooring
- / Swimming pools & Spa

Indoor

Outdoor





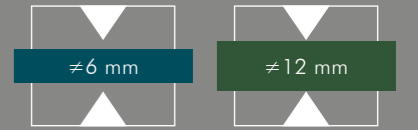

Le lastre in 12mm di spessore through body sono particolarmente indicate per il rivestimento di piani di lavoro, piani cucina, mobili da bagno. Il materiale viene prodotto utilizzando un solo strato di materiale prezioso, che attraversa la lastra fino al fondo, in modo che sia possibile lavorare i bordi come se fosse una pietra naturale, ma mantenendo tutte le caratteristiche migliorative del gres porcellanato tecnico non smaltato.

Our 12mm through body slabs are particularly indicated for countertops, kitchen tops and vanity tops. The material is manufactured by using one single layer of precious powders that runs through the body of the tile from the top to the bottom. This allows then to process the material as if it was a natural stone, by rounding and refining the edges, but keeping all the pluses of the technical porcelain stonewar.

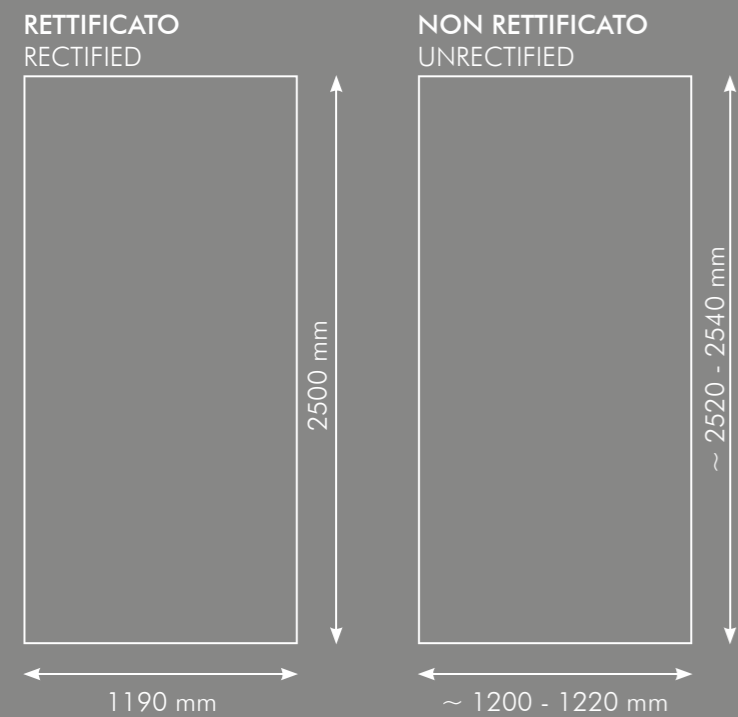

COLORI DISPONIBILI | COLOURS AVAILABLE:

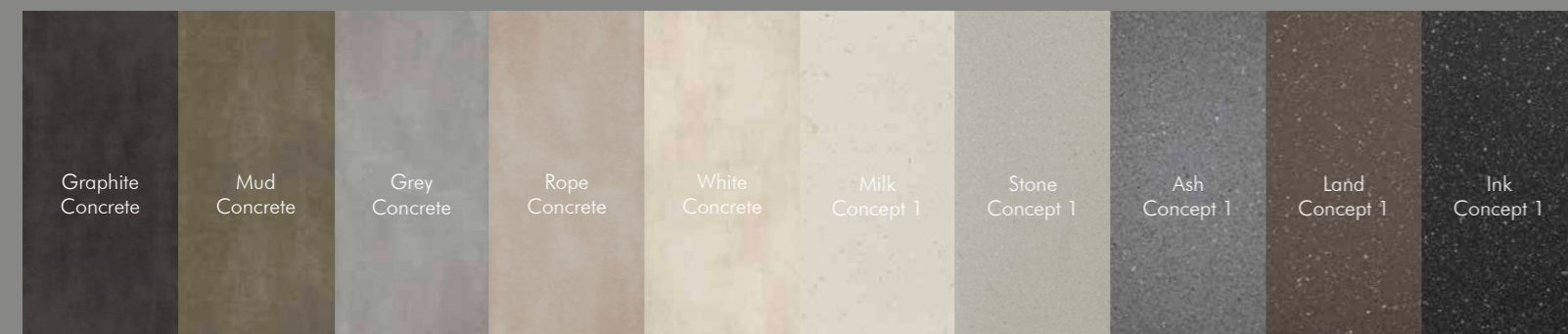

LAVORAZIONI BORDI | EDGES MACHINING



LAVORAZIONI TOP | WORKTOP MACHINING





LAVABI | WASHBASINS

Middle

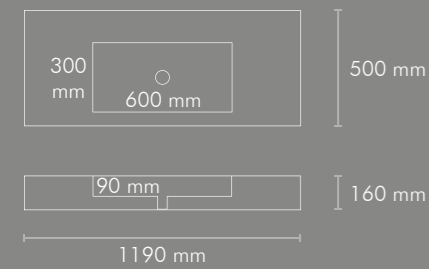

Tutti i colori in 4.8 e 6 mm.  
All colours in 4.8 and 6 mm thickness.

Right

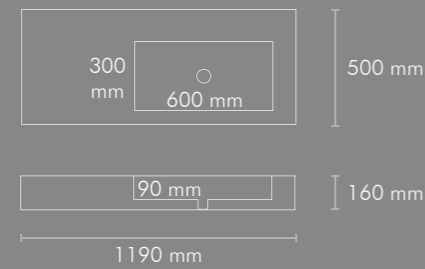

Tutti i colori in 4.8 e 6 mm.  
All colours in 4.8 and 6 mm thickness.

Left

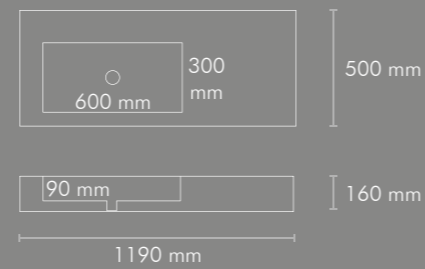

Tutti i colori in 4.8 e 6 mm.  
All colours in 4.8 and 6 mm thickness.

Double

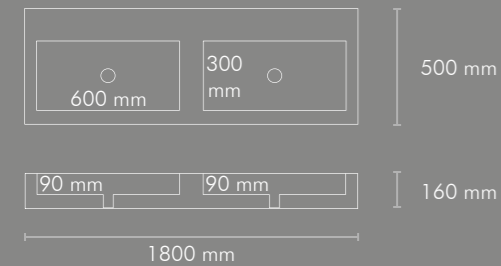

Tutti i colori in 6 mm nel formato 120x250 cm.  
All colours in 6 mm thickness in 120x250 cm size.

Copertura vasca opzionale | Opzional basin cover

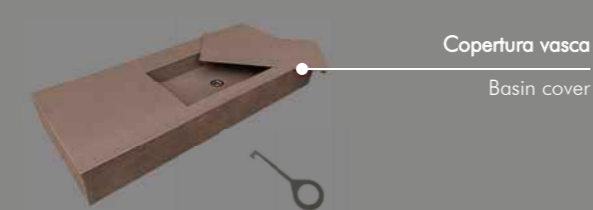

Staffe, piletta e sifone sono inclusi.  
Brackets, drain and siphon are includes.



Tutte le informazioni tecniche inerenti ai lavabi le puoi trovare sulla brochure "Lavabi e piatti doccia Gigacer".  
You can find all technical information about washbasins in our brochure "Washbasins and shower trays Gigacer".

Per dimensioni o spessori diversi da quelli rappresentati in tabella contattare Gigacer Service.  
For inquiries concerning different thicknesses and sizes from the ones indicated in the table, please contact Gigacer Service.

PIATTI DOCCIA | SHOWER TRAYS

Modello A

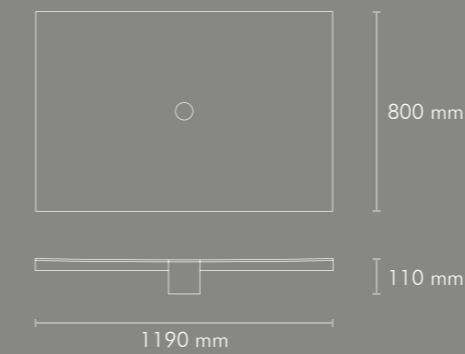

Tutti i colori in 4.8 e 6 mm.  
All colours in 4.8 and 6 mm thicknesses.

Modello B

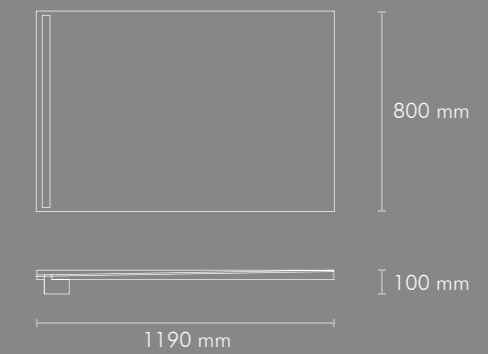

Tutti i colori in 4.8, 6 e 12 mm.  
All colours in 4.8, 6 and 12 mm thicknesses.



Sono inclusi canalina o piletta.  
Drain channel or drain are includes.



Tutte le informazioni tecniche inerenti ai piatti doccia le puoi trovare sulla brochure "Lavabi e piatti doccia Gigacer".  
You can find all technical information about shower trays in our brochure "Washbasins and shower trays Gigacer".

Per dimensioni o spessori diversi da quelli rappresentati in tabella contattare Gigacer Service.  
For inquiries concerning different thicknesses and sizes from the ones indicated in the table, please contact Gigacer Service.





Gigacer Service è il servizio di lavorazioni su misura offerto da Gigacer su tutti i suoi prodotti. Consente di tagliare, forare, lucidare e in generale adattare le lastre al singolo progetto, seguendo le indicazioni di uno specifico disegno del cliente. In questo modo le lastre ceramiche possono essere utilizzate sia per realizzare elementi d'arredo, sia per personalizzare o adeguare al progetto le dimensioni di lastre per pavimento o rivestimento. Il pavimento o il rivestimento potrà così essere abbinato o addirittura identico al top cucina, ai gradini della scala, al top bagno o anche allo stesso lavabo, in una infinità possibilità di forme e dimensioni. Il pezzo unico viene realizzato anche seguendo le indicazioni e il disegno tecnico del progettista.

Gigacer Service is the firm's made to measure working service offered on all products. It enables slabs to be cut, perforated, polished and generally adapted to the individual project in line with the requisites of a specific client design. In this way the ceramic slabs can be used both to create decor elements and to personalise or adjust slab dimensions to flooring or decor designs. In this way the ceramic slabs can be matched with, or even identical to, the kitchen worktop, flights of steps, the bathroom worktop and even the basin in an infinity of possible forms and dimensions. Each single piece can be made in accordance with designers' instructions and technical drawings.





BATTISCOPIA | SKIRTING

Battiscopa 60  
≠ 12mm

Battiscopa 120  
≠ 4.8mm

Battiscopa 120  
≠ 6mm

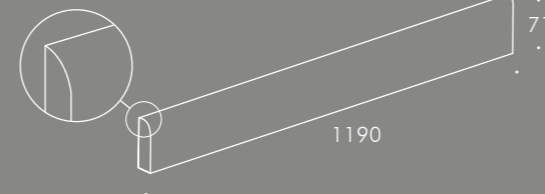
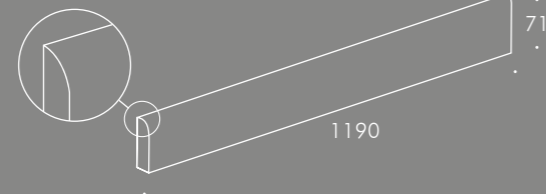
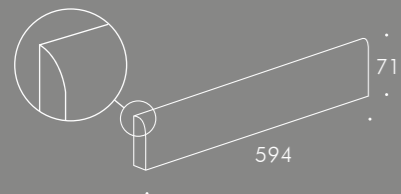

**Utilizzo:** pezzi di finitura che consentono di proteggere la parte bassa della parete durante le quotidiane operazioni di pulizia.  
**Dettagli:** La parte superiore del battiscopa 12mm viene arrotondata e smaltata a freddo per nascondere gli strati del multilayer. I battiscopa 4,8mm, 6mm e 12mm su materiale a piena massa, non necessitano di smaltatura.

Use: finishing pieces that protect the lower part of the walls during everyday cleaning and maintenance operations.  
Details: the top of the 12mm thickness skirting pieces is cold glazed to hide the layers of the multilayer porcelain. 4.8-6-12mm skirtings are not glazed on the nose, as they are made of through body porcelain.

GRADONI VELA | VELA STEPTREADS

Vela 120

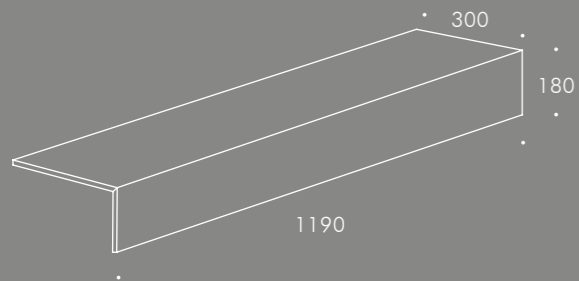

**Utilizzo:** gradini per scale.

Use: steptreads for stairs.

GRADONI COSTA RETTA | COSTA RETTA STEPTREADS

Costa retta 60

Costa retta 120

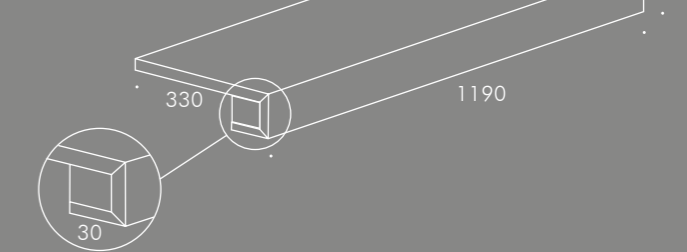
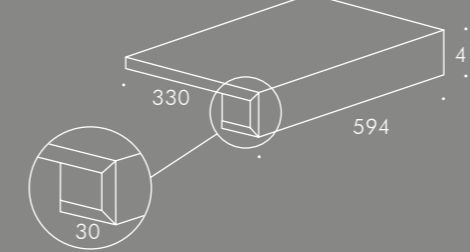

**Utilizzo:** gradini per scale, davanzali, finitura terrazze e balconi, bordo piscine, interno o esterno.

Use: steptreads for stairs, windowsills, terraces and balconies edge finish, poolside, indoor or outdoor.

MODIFICHE SU RICHIESTA | CHANGES ON REQUEST



È possibile richiedere la fattibilità e la quotazione per le seguenti modifiche:  
1- top squadrato invece che arrotondato  
2- top non smaltato (nel 12mm sarà visibile il multilayer)  
3- misure non standard: indicare misura X e Y in mm

It is possible to require the feasibility and the quotation for the following changes:  
1- squared top edge, instead of rounded  
2- unglazed top edge (on 12mm thickness the multilayer will be visible)  
3- bespoke sizes: please indicate X and Y in mm

Le misure X, Y, Z e J sono modificabili a piacimento.  
È possibile richiedere il gradone con chiusura su un lato o su entrambi, nel caso la scala sia aperta.  
Il pezzo può essere realizzato anche a vela senza rientranza.  
È necessario indicare tutte le misure richieste (X, Y e Z).

It is possible to request bespoke sizes on X, Y, Z and J.  
It is possible to ask for one or both sides closed, if the staircase is open.  
The piece can be made without nose, only at 90°.  
All sizes must be specified (X, Y and Z).

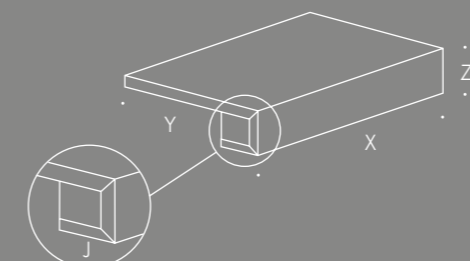
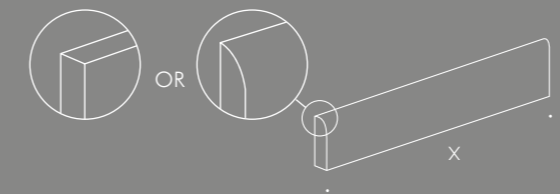





DESTINAZIONI D'USO | INTENDED USE CLASSIFICATION

	Pavimenti nuove costruzioni New floors	Pavimenti in ristrutturazioni Floor renovation	Rivestimenti Wall covering	Commerciale leggero Light commercial	Commerciale pesante Heavy commercial	Esterni Outdoor	Soprelevato Raised floor	Piani di lavoro Countertops kitchentops
4.8 mm 6 mm	+	++	++	+	--	-	--	-
12 mm multilayer	++	+	+	++	++	+	+	-
12 mm through body	-	-	-	-	-	-	-	++
24 mm	-	-	-	-	++	++	++	-
	Posa a terra in nuove costruzioni sumassetto  Floor tiling on screed in new buildings	Posa a terra su pavimenti esistenti, in ceramica o pietra naturale, o su massetto in costruzioni in stato di ristrutturazione  Floor tiling on screed or on existing floor (in ceramic or natural stone) in buildings under renovation	Rivestimento muri  Wall covering	Ambienti pubblici interni a medio traffico  Indoor public places subject to medium pedestrian traffic	Ambienti pubblici interni ad alto traffico  Indoor public places subject to heavy pedestrian traffic	Ambienti esterni  Outdoor places	Pavimenti soprelavati con struttura flottante o posa su supporti in PVC  Raised floor with floating structure or PVC supports	

- ++ Consigliato | Recommended
- + Appropriato | Suitable
- Non consigliato | Not recommended
- Non appropriato | Not suitable

SUGGERIMENTI PER LA POSA | INSTALLATION SUGGESTIONS

Le lastre di 4.8 mm e 6mm sono: resistenti, sottili, leggere, facili da movimentare e da tagliare, resistenti al fuoco, ingelive, ecocompatibili e non necessitano di particolari accorgimenti per la manutenzione. È un prodotto ideale per pavimenti e rivestimenti interni ed esterni, ed è particolarmente adatto nel caso di ristrutturazione di pavimentazioni e rivestimenti residenziali: si applica sull'esistente senza opere di demolizione e relativi costi di smaltimento. Il nostro porcellanato sottile è abbinabile ai pavimenti della stessa collezione in spessore tradizionale, dei quali mantiene non solo le stesse caratteristiche estetiche, ma anche il medesimo calibro e modularità. Il 4.8mm/6mm è un prodotto dal design ecologico: lo spessore ridotto comporta un minor impatto ambientale in termini di consumo di energia, materie prime, imballo e trasporti. Costituisce una valida alternativa al gres porcellanato di spessore tradizionale in tutti i casi in cui il minor spessore e la leggerezza costituiscono un fattore determinante. In fase di posa, le lastre di spessore 4,8 mm e 6 mm risultano perfettamente complanari.

SUGGERIMENTI PER LA POSA

INCOLLAGGIO: Doppia spalmatura (sul fondo e sul retro della piastrella)

TAGLIO: Normale taglierina da cantiere, sega a dischi diamantati.

FORATURA: trapani a punta per gres porcellanato, frese a tazza, idrogetto.

Non usare il percussore e raffreddare con acqua nel punto di contatto.

4.8mm and 6mm slabs are resistant, thin, lightweight, easy to handle and cut, fire-resistant, frostproof, environmentally friendly and require no special care for maintenance. 4.8mm/6mm is an ideal product for interior and exterior cladding. 4,8mm/6mm slabs are particularly suitable in the case of renovation of residential floors and walls: they can be laid on the existing floor, allowing for a dramatic demolition and disposal cost savings. GIGACER 4.8mm is suitable for indoor and outdoor wall covering and it is particularly indicated in all cases where it is preferable not to load too much weight on the building's structure. 4.8mm/6mm can be combined with the 12mm slabs of every collection because it has the same caliber and it is perfectly modular with 2mm joints. 4.8mm/6mm is a green product: it allows savings in terms of energy consumption, raw materials, packaging and transport. It is a valid alternative to the traditional 12mm in all those cases where lightness and less thickness represent a determinant variable.

4.8 mm and 6mm tiles can be fixed together on the same surface, as the real difference in thickness is minimal.

INSTALLATION SUGGESTIONS

GLUING: Double spreading (on substrate and on the back of the tile).

CUTTING: Standard dry diamond clipper for porcelain tiles, bench machines with diamond disks.

DRILLING: Drills with porcelain drill tips, hollow mills or hose-mounted drill bits (for large size holes), hydrojet.

Never use the hammer function when drilling.



La resistenza di 2 lastre di 12mm di spessore, incollate assieme con colla speciale garantisce un modulo di rottura di 18.140 kgf.  $\neq 24$ mm è resistente al gelo, ha un altissimo carico di rottura, è resistente ai sali, facile da pulire anche utilizzando idropulitrici, resistente agli attacchi di muffe, funghi, muschi e trattamenti al verderame. È rimovibile, riutilizzabile, antiscivolo, resistente al fuoco e facile da installare.  $\neq 24$ mm non cambia col tempo e resiste a tutte le condizioni climatiche, caratteristiche fondamentali per un pavimento esterno. La posa può essere fatta utilizzando diverse tecniche, secondo il tipo di superficie da ricoprire. Le lastre possono essere installate a secco direttamente su ghiaia, sabbia o altri substrati, possono essere stese su supporti sopraelevati (es. Eterno Ivica Pedestal) o incollate. L'installazione sopraelevata può essere effettuata con una struttura portante di moduli in polipropilene, che possono essere fissi, regolabili e autolivellanti. Hanno una altezza minima di 37,5 mm e massima di 230 mm. L'installazione sopraelevata consente una facile ispezione di cavi o condutture senza dover rompere il pavimento.  $\neq 24$ mm pavimento sopraelevato è la migliore soluzione per luoghi residenziali o commerciali come balconi, vialetti, ecc. dal momento che protegge la superficie sottostante e consente ogni tipo di intervento tecnico. Consigliamo una fuga di 4mm per lo scolo dell'acqua.

The strength of 2 12mm thick tiles glued together with a special glue grants a modulus of rupture of 18.140 Kgf.  $\neq 24$ mm is frostresistant, has a very high breakage load, it is resistant to salts, easy to clean also using pressure washers, resistant to the attack of mould, moss and verdigris treatments, removable, reusable, anti-slip, fire-resistant and very easy to install.  $\neq 24$ mm does not change and lasts over time in any climatic conditions, characteristics that are a must for outdoor floor coverings. Installation can be done using different techniques, according to the kind of surface. The porcelain stoneware slabs can be laid using a dry installation system, directly onto gravel or sand substrates as well as with raised installation (i.e. Eterno Ivica Pedestals) or glued. Raised installation is made with a support structure made of polypropylene, prefabricated, load-bearing modules, which can be fix, adjustable and self levelling. They have a minimum height of 37,5mm and a Maximum height of 230mm. Raised installation allows for easy inspection of underlying cabling and circuits without the need for burdensome work.  $\neq 24$ mm raised floor is the best solution for residential and commercial destinations such as balconies, paths, access floors, etc., Protecting the under-space and easily allowing any kind of technical intervention. A 4 mm joint is requested for water drainage.

PIEDINI IN POLIPROPILENE | POLIPROPYLENE SUPPORTS

120x120 · 48"x48"	60x120 · 24"x48"	60x60 · 24"x24"
9 pz/lastra 9 pcs/slab	6 pz/lastra 6 pcs/slab	4 pz/lastra 4 pcs/slab
80 kg	40 kg	20 kg

I VANTAGGI DEL 24MM | THE ADVANTAGES OF 24MM

- Possibilità di avere un prodotto con lo stesso tono e superficie posato nelle aree interne ed esterne
- Grande formato 120x120 in 24mm di spessore
- Possibilità di avere un pavimento antiscivolo all'esterno con posa facilitata
- Drenaggio efficace
- Posa a secco
- Durata e resistenza
- Pulibilità
- Ingelività

Lo stucco del bordo del 24mm è colorato in tinta con il fondo scelto.  
Esempi di utilizzo del 24mm: pavimento sopraelevati / terrazzi all'aperto / terrazze chiuse / vialetti esterni / facciate ventilate / spiagge piscine / piatti doccia.

- Possibility to have a product with the same tone and surface for indoor and the outdoor spaces
- Big format 120x120 24 mm thickness
- Possibility to have an antislip material for the outdoor with easy lay
- Efficient drainage
- Dry laying
- Endurance and strength
- Cleanability
- Frost reistance

The grout in the 24mm thickness has the same colour of the tiles.  
Some examples using 24mm: raised access floors / open terrances / closed terraces / walkways / swimming pools / gardens / shower trays.





## POSA E COLLA | INSTALLATION AND ADHESIVES

IL SUPPORTO

Il massetto o il substrato deve essere sufficientemente resistente a sopportare il peso aggiuntivo previsto con l'installazione del pavimento in ceramica, deve essere perfettamente planare, perfettamente maturo (da 28 giorni di presa o secondo indicazioni del produttore del cemento) e libero da qualsiasi detrito o liquido sulla superficie (polvere, sabbia, terra, olio, vernice, grasso, ecc.) che possa compromettere l'adesione della ceramica al supporto.

SUPPORTI IN CEMENTO RINFORZATO

Il supporto deve essere maturo, pulito, asciutto e libero da qualsiasi sostanza che possa compromettere l'adesione della ceramica al substrato. Ogni crepa formatasi a seguito del restringimento idrometrico del supporto deve essere sigillata con adesivo bicomponente epossidico (es. EPORIP di Mapei spa o simili). Se il supporto presenta tracce di polvere o sporco deve essere pulito accuratamente e successivamente deve essere applicato uno strato di primer in resina monocomponente con contenuto di componenti organici volatili (VOC) molto basso (es. PRIMER G o ECO PRIM T di Mapei spa o simili). Se la superficie del cemento presenta parti scrostate o indebolite è necessario consolidarle con un primer epossidico o in poliuretano mono o bicomponente (come PRIMER MF o ECOPRIM PU 1K di Mapei spa o simili).

MASSETTI

Il massetto deve essere maturo (28 giorni di presa o secondo indicazioni del produttore del cemento), pulito, asciutto e libero da qualsiasi sostanza che possa compromettere l'adesione della ceramica al substrato. Ogni crepa formatasi a seguito del restringimento idrometrico del supporto deve essere sigillata con adesivo bicomponente epossidico (es. EPORIP di Mapei spa o simili). Una volta che la superficie è completamente liscia e matura è necessario controllare che abbia la resistenza necessaria a sopportare le sollecitazioni e il peso ai quali sarà sottoposta con la posa della ceramica. Se il supporto presenta tracce di polvere o sporco deve essere pulito accuratamente e successivamente deve essere applicato uno strato di primer in resina monocomponente con contenuto di componenti organici volatili (VOC) molto basso (es. PRIMER G o ECO PRIM T di Mapei spa o simili). Se la superficie del cemento presenta parti scrostate o indebolite è necessario consolidarle con un primer epossidico o in poliuretano mono o bicomponente (come PRIMER MF o ECOPRIM PU 1K di Mapei spa o simili). Per pavimenti riscaldati deve essere eseguito il corretto ciclo del sistema in conformità con le norme vigenti e le indicazioni del produttore del sistema di riscaldamento a pavimento.

PAVIMENTI ESISTENTI IN CERAMICA, COTTO O PIETRA

Per il fissaggio delle lastre su pavimenti esistenti controllare per prima cosa che il pavimento esistente sia ancora solidamente attaccato al substrato, che sia planare e non siano presenti rotture o parti distaccate. Se queste condizioni non sono interamente soddisfatte procedere come segue:

- Sigillare le crepe e le rotture con una resina epossidica bicomponente (come EPORIP di Mapei spa o simili)
- Riempire i vuoti lasciati da eventuali pietre o piastrelle rimosse usando un prodotto livellante (come ADESILEX P4 o NIVORAPID di Mapei spa o simili)
- Correggere ogni imperfezione di planarità con malte livellanti dopo aver pulito la superficie e aver usato, se necessario, un primer (come ECO PRIM T di Mapei o simili).

In generale i pavimenti esistenti in ceramica o pietra naturale devono essere accuratamente puliti con una soluzione di acqua tiepida e soda caustica al 20%, e sciacquati abbondantemente per rimuovere ogni traccia di sostanza. In alcuni casi la superficie può essere sottoposta ad abrasione, per ottenere un supporto più ruvido e aumentare l'aderenza delle colle.

LA POSA

Prima di installare le lastre Gigacer occorre selezionare l'adesivo più adatto a seconda del tipo di supporto, delle condizioni climatiche e del tempo che intercorrerà tra la posa e l'inizio dell'utilizzo della superficie calpestabile. La tabella seguente illustra alcuni esempi di adesivi adatti alla posa delle lastre Gigacer, sia di 12mm che di 4,8mm di spessore.

ADESIVI CONSIGLIATI

Ardex

Mapei

Kerakoll

Per una posa perfetta e una completa bagnatura consigliamo, soprattutto in caso di utilizzo delle lastre sottili in 4,8mm e 6mm, di effettuare la doppia spalmatura, applicando la colla sia sul retro della lastra che sul supporto. Applicare prima uno strato sottile di colla sul retro della lastra con una spatola liscia, e di seguito applicare altro adesivo stendendolo con una spatola dentata effettuando movimenti semicirculari. Applicare poi la colla sul sottofondo con una spatola dentata e posare la lastra. Battere la lastra con un martello di gomma per assicurarsi della perfetta bagnatura e scongiurare la presenza di vuoti d'aria. È possibile utilizzare sistemi per agevolare la perfetta planarità della posa, soprattutto con lastre di grande formato, come ad esempio il Tuscan Leveling System.

STUCCATURA

Consigliamo una fuga di 2mm in caso di posa multiformato e 2-4mm in caso di posa di un formato unico. È necessario consultare le nostre tabelle di caratteristiche tecniche e applicare i giunti di dilatazione necessari. Lo stucco deve essere applicato solo dopo che l'adesivo si sia indurito, normalmente dopo 3 ore in caso di adesivo rapido e dopo 24 ore in caso di adesivo standard. Questi valori si riferiscono ad una posa all'asciutto effettuata a una temperatura di +23°C e con il 50% di umidità relativa.

THE SUBSTRATE

The floor substrate must be resistant enough to bear the expected stress and weight added with the ceramic tiles, it must be perfectly planar, perfectly aged (aged 28 days or according to the manufacturer's specifications) and dry, and free of any loose part such as oil, water, dust, paint, grease etc., which might compromise the adhesion of the slabs.

REINFORCED CONCRETE SUBSTRATE

The substrate must be aged, cured, clean, dry and free of any substance which might compromise the adhesion of the ceramic. Any crack due to hygrometric shrinkage must be sealed using a two-component epoxy fluid adhesive (ie. EPORIP by Mapei or similar). If the concrete support is dirty or has surface dust it must be thoroughly cleaned and the a suitable single-component resin primer with a very low content of colatile organic compounds (VOC) must be applied (ie. PRIMER G or ECO PRIM T by Mapei spa or similar). If the concrete surface has any surface inconsistencies it must be consolidated with a suitable single-component or two-component epoxy or polyurethane primer (such as PRIMER MF or ECOPRIM PU 1K by Mapei spa or similar).

SCREED COATS

The screed surface must be aged (aged 28 days or according to the manufacturer's specifications), cured, clean, dry and free of any substance which might compromise the adhesion of the ceramic. Any crack due to hygrometric shrinkage must be sealed using a two-component epoxy fluid adhesive (ie. EPORIP by Mapei or similar). Once the surface is completely cured it is important to check that it is strong enough to bear the weight of the ceramic that will be fixed on it. If the concrete support is dirty or has surface dust it must be thoroughly cleaned and the a suitable single-component resin primer with a very low content of colatile organic compounds (VOC) must be applied (ie. PRIMER G or ECO PRIM T by Mapei spa or similar). If the concrete surface has any surface inconsistencies it must be consolidated with a suitable single-component or two-component epoxy or polyurethane primer (such as PRIMER MF or ECOPRIM PU 1K by Mapei spa or similar). For floor heating installations the correct switch on cycle of the system must be performed in compliance with the applicable standards and the indications of the manufacturer of the floor heating system.

EXISTING CERAMICS OR STONE FLOORINGS

For ceramic and stone floorings, check that the existing covering is perfectly attached to the support, planar and free of any cracks or sections that tend to detach from the substrate. If not proceed as follows:

- seal the floor cracks with two-component fluid epoxy resins (such as EPORIP by Mapei spa or similar);
- fill any gaps created when removing any tiles or slabs that do not adhere, using rapid setting thixotropic smoothing compounds (such as ADESILEX P4 or NIVORAPID by Mapei spa or similar);
- correct any planarity imperfections with levelling mortars, after cleaning the existing surface and, if necessary, using a suitable primer (such as ECO PRIM T by Mapei spa or similar).

Generally speaking existing ceramic or stone floorings must be suitably cleaned with a solution of warm water and caustic soda at 20%, and rinsed thoroughly to remove any trace of loose substances. In specific cases the surface can be subjected to some surface abrasion to achieve a rough and clean support, in order to improve the subsequent adhesion.

TILES INSTALLATION

Before laying Gigacer slabs select the most suitable adhesive according to the type of support, the final environment, the weather conditions of the site and the time available between laying and use. The table below lists a few examples of adhesive systems suitable for laying our slabs on horizontal indoor surfaces.

SUGGESTED ADHESIVES

Ardex

Mapei

Kerakoll

For a perfect installation and a complete wetting we suggest to apply the adhesive with double spreading, applying the glue both on the substrate and on the back of the tile. We suggest to use this procedure especially for 4,8mm and 6mm slabs.

Apply the adhesive with an adequately sized notched trowel, firstly laying one thin layer on the support with the flat edge of the trowel and then applying the desired thickness with the notched edge. Then apply the adhesive on the substrate with a notched trowel and lay the tile. Beat the tile with a rubber hammer to ensure perfect wetting and remove any air bubble which might have generated between the tile and the substrate. It is possible to use systems such as Tuscan Leveling or similar to help maintaining the perfect planarity of the floor.

GROUTING

We suggest to use 2mm joints in case of multi-format flooring and 2-4 mm in case of single-format. Please read carefully our technical specifications charts and apply the necessary dilatation joints. The joints must be grouted only after the adhesive has hardened, normally 3 hours for fast set adhesives and at least 24 hours for regular set adhesives. These values refer to laying carried out at +23°C and 50 % relative humidity.



PULIZIA E MANUTENZIONE | CLEANING AND MAINTENANCE

SURFACES CLEANING	MADE 2.0 LEVIGATO CONCEPT 1 LEVIGATO	MADE 2.0 BOCCIARDATO ARGILLA QUARTZ ARGILLA MATERIAL CONCRETE KREA DECO LE CORBUSIER LCS CERAMICS POINTILLE CONCEPT 1 QUARRY
<b>Pulizia dopo posa</b> Initial cleaning	Deterdek Pro ÈCOSÌ Cherodal	Deterdek Pro ÈCOSÌ Cherodal
<b>Protezione superficiale</b> Surface protection	Fila MP90	/
<b>Pulizia ordinaria</b> Daily maintenance	Cleaner Pro ÈCOSÌ Velvet	Cleaner Pro ÈCOSÌ Velvet
<b>Pulizia straordinaria</b> Extraordinary cleaning	PS87 Pro / SR95 ÈCOSÌ Mic One	PS87 Pro / SR95 ÈCOSÌ Mic One
<b>TIPO DI SPORCO</b>	<b>DETERGENTE</b>	
<b>Grassi animali e vegetali, gelato, succhi di frutta, the, macchie di verdura</b> Animal and vegetable grease, ice cream, fruit juices, tea, vegetable stains	<b>Detergente a base alcalina: PS87 Pro</b>	
<b>Vino, birra, aceto, caffè, inchiostri, pennarelli, nicotina, urina, vomito, coca cola, tintura per capelli</b> Wine, beer, vinegar, coffee, inks, markers, nicotine, urine, vomit, coca cola, hair dye	<b>Detergente a base alcalina: PS87 Pro o smacchiante SR95 o ÈCOSÌ Mic One</b>	
<b>Depositi efflorescenze calcare, ruggine, malte, segni metallici, cera protettiva antiabrasione</b> Limescale, rust, mortar, metallic marks, anti-abrasion protective wax deposits	<b>Detergente a base acida: Deterdek Pro o ÈCOSÌ Cherodal</b>	
<b>Resine, bitume, cere di candele, catrame, residui di scotch</b> Resins, bitumen, candle waxes, tar, scotch residues	<b>Solvente SOLV</b>	
<b>Vernice, graffiti</b> Paint, graffiti	<b>Detergente a base alcalina: PS87 Pro o sverniciante FILA NO PAINT STAR</b>	

PULIZIA STRAORDINARIA | INTENSIVE MAINTENANCE

TIPO DI MACCHIA TYPE OF SPOTS	ECOSÌ	FILA	SOLVENTI SOLVENTS	ACIDI ACIDS	ALCALI ALKALI
<b>Birra</b> Beer	Mic One	PS87 Pro			•
<b>Caffè</b> Coffee	Mic One	PS87 Pro			•
<b>Calcicare</b> Limescale marks	Cherodal	Deterdek Pro		•	
<b>Catrame</b> Tar	Mic One	PS87 Pro	•		
<b>Cemento</b> Cement	Cherodal	Deterdek Pro		•	
<b>Cera di candela</b> Candle wax	<b>Acqua calda + terra</b> Hot water	<b>Acqua calda</b> Hot water	•		•
<b>Coca cola</b> Cola	Mic One	PS87 Pro		•	•
<b>Colla</b> Glue	Cherodal	Deterdek Pro	•		
<b>Gelato</b> Ice-cream	Mic One	PS87 Pro			•
<b>Gomma da masticare</b> Chewing gum	<b>Ghiaccio secco</b> Dry ice	<b>Ghiaccio secco</b> Dry ice	•		•
<b>Gomma di pneumatico</b> Tyre rubber	Mic One	PS87 Pro	•		•
<b>Inchiostro</b> Ink	Mic One	PS87 Pro	•		•
<b>Nicotina</b> Nicotine	Mic One	PS87 Pro			•
<b>Pennarello</b> Marker	Mic One	PS87 Pro	•		•
<b>Resine</b> Resin	Mic One	PS87 Pro	•		
<b>Ruggine</b> Rust	Cherodal	Deterdek Pro		•	
<b>Smalto per unghie</b> Nail-polish	Mic One	PS87 Pro	•		
<b>Sangue</b> Blood	Mic One	PS87 Pro			•
<b>Sigaretta</b> Cigarette	Mic One	PS87 Pro		•	
<b>Verince murale</b> Wall painting	Cherodal	Deterdek Pro		•	
<b>Vino</b> Wine	Mic One	PS87 Pro			•
<b>Olio</b> Oil	Mic One	PS87 Pro			•
<b>Grasso</b> Grease	Mic One	PS87 Pro			•



## CONSIGLI PER LA PULIZIA | CLEANING TIPS

I prodotti GIGACER vengono sottoposti continuamente a tutti i test di resistenza alle macchie previsti dalle norme UNI EN. La superficie di una piastrella completamente greificata è composta da materiale simile al vetro e come tale va trattata in fase di pulizia.



## PULIZIA INIZIALE

La prima pulizia dopo la posa è la più importante nella intera vita del pavimento. Serve a rimuovere qualsiasi residuo di stucco, colla, cemento, calce o boiacca, che se lasciati sulla superficie delle lastre possono minare definitivamente le caratteristiche di pulibilità del pavimento in ceramica. Non utilizzare mai strumenti meccanici per la prima pulizia: la rimozione dei residui di stucco e colla è un procedimento chimico.

STUCCO UTILIZZATO	QUANDO FARE LA PULIZIA	COSA USARE	MODALITA' D'USO
Stucco cementizio miscelato con acqua	Dopo 2/3 giorni ed entro 7 giorni dalla stuccatura	Detergente a base acida - Deterdek Pro o ECOSì Cherodal	Seguire le istruzioni fornite dal produttore del detergente. Testare preventivamente il detergente su una piastrella non posata o in posizione nascosta prima dell'uso, in particolare su prodotti lappati, lucidati o levigati. Le superfici da pulire devono essere inumidite con acqua prima del lavaggio. Lasciare agire il prodotto per alcuni minuti, sempre seguendo le istruzioni del produttore. A fine lavaggio raccogliere il liquido dal pavimento e sciacquare abbondantemente con acqua. Raccogliere l'acqua di risciacquo con aspiraliquidi o strofinaccio. Ripetere l'operazione di risciacquo fino a che tutti i residui acidi non sono stati rimossi.
Stucco epossidico, bi-componente e reattivo	Immediatamente	Seguire le indicazioni del produttore dello stucco	La pulizia deve essere eseguita subito ed accuratamente, dal momento che questo tipo di stucchi indurisce molto rapidamente, anche nel giro di pochi minuti. Seguire tassativamente le modalità di pulizia indicate dal fabbricante dello stucco e verificarne l'efficacia con una prova preliminare di pulizia prima di procedere alla stuccatura dell'intera superficie piastrellata. Verificare bene che tutto lo stucco venga debitamente rimosso anche osservando la superficie controluce.

La pulizia delle superfici bocciardate è più laboriosa. Consigliamo di procedere rapidamente e di utilizzare spazzole che possano raggiungere anche le aree più difficili.

Se la pulizia iniziale non è stata fatta correttamente è possibile che si notino sul pavimento residui, patine lucide o aloni localizzati in particolare attorno alle fughe. In questi casi è necessario ripetere l'operazione di pulizia iniziale dopo posa, eventualmente utilizzando i detergenti in concentrazioni maggiori e lasciandoli agire più a lungo. Gli stucchi, una volta asciugati, sono di difficilissima rimozione, a volte impossibile. Contattare il produttore dello stucco.

## PULIZIA QUOTIDIANA

Per la pulizia quotidiana è sufficiente asportare la polvere con un panno in microfibra, lavare la superficie con il detergente neutro a basso residuo VELVET ECOSì o Cleaner Pro diluiti in acqua come indicato dal produttore (circa una tazzina in un secchio da 5 litri d'acqua) utilizzando uno straccio umido che andrà sciacquato spesso nella soluzione. È essenziale utilizzare un detergente neutro privo di cere, acidi, solventi o componenti abrasive. L'uso di acqua sporca o prodotti lucidanti o un eccesso di detergenti può, col tempo, formare una patina invisibile sulla superficie delle lastre, causa di aloni e macchie. Non utilizzare mai smacchiatori tipo antiruggine o di tipo spray perché spesso contengono acido fluoridrico, che danneggerebbe irreparabilmente il pavimento. È bene impermeabilizzare le fughe con il protettivo per fughe tipo FUGAPROOF della FILA, il quale impedisce l'assorbimento di macchie, facilita la rimozione dello sporco e mantiene la fuga come nuova per lungo tempo.

Se la pulizia quotidiana non viene effettuata correttamente è possibile che appaiano aloni opachi, che il pavimento risulti più lucido di quanto non dovrebbe o che rimangano impronte al passaggio. In questi casi è bene applicare un detergente tipo Cleaner Pro non diluito e lasciare agire per 5-10 minuti. Quindi frizionare con un tampone o uno straccio. Risciacquare abbondantemente e raccogliere i liquidi con uno straccio o una macchina aspiraliquidi. Asciugare infine con un panno in microfibra.

Gigacer non sarà mai responsabile per alterazioni superficiali che possano avvenire sul pavimento se questo viene pulito con procedimenti meccanici e non con i prodotti e i procedimenti indicati in questa guida.

GIGACER products are constantly controlled and undergo all kind of stain resistance tests recommended by UNI EN. The surface of a perfectly vitrified tile is made by a material similar to glass and it must be treated like glass when it must be cleaned.



## INITIAL CLEANING

The first cleaning after installation is the most important in the whole life of the floor. It is made to remove any residue of grout, glue or cement, that if are left on the surface of the slabs might compromise the stain resistance properties of the ceramic floor. Never use mechanic machines for initial cleaning: grout and glue residues removal is a chemical process.

TYPE OF GROUT	WHEN IT MUST BE CLEANED	WHAT TO USE	HOW TO CLEAN IT
Cementitious grout mixed with water	After 2/3 days and within 7 days from grouting	Acide detergent - Deterdek Pro or ECOSì Cherodal	Follow the instructions provided by the producer of the cleaning solution. Previously test the detergent on a tile that hasn't been installed or on a hidden part of the floor before using the detergent on the whole surface, in particular on honed or polished floors. The surface must be moistened with water before washing. Leave the solution on the floor for some minutes, always following the instructions of the cleaning solution producer. Then collect the liquids and rinse thoroughly with water. Absorb the water with a rug or a vacuum machine until all the residues have been removed. Repeat rinsing operations if needed, until all residues will have been removed.
Epoxy or bi-component grouts	Immediately	Follow the instructions of the grout producer	Cleaning must be done immediately and very carefully, because this kind of grouts harden very quickly. Strictly follow the instructions provided by the grout producer and previously verify their effectiveness on a loose tile before proceeding with grouting operations on the whole area. Check carefully that all grout residues have been removed by observing the surface backlight.

Cleaning bush-hammered surfaces is more demanding. We suggest to proceed immediately and to use brushes that can reach even the most difficult area.

If the initial cleaning has not been carried out correctly it is possible to see residues or stains on the floor, especially along the joint spacings. In these cases it is necessary to repeat the initial cleaning operation, using the cleaning solutions in higher concentrations and leaving them longer on the floor. It is very difficult to remove grout once it's dry. Please contact the grout producer in case of problems.

## DAILY MAINTENANCE

For daily maintenance we suggest to remove dust with a microfiber cloth, then wash the surface with a neutral detergent with low residue, like VELVET ECOSì or Cleaner Pro diluted in water as indicated by the producer (about 3 spoons in a 5 litres of water) using a wet cloth. The cloth must be washed very often in the water and detergent solution. It is crucial that the solution used is neutral, without wax, acids, solvents or abrasive particles. Using dirt water, polishing products or too much detergent can form an invisible layer on the surface of the slabs, causing stains and allowing the floor to retain dust. Never use stain removers, anti rust or spray because they often contain hydrofluoric acid that would damage the floor irreparably.

We suggest to waterproof the grouted joints with FILA's FUGAPROOF, that prevents water absorption by the joints, makes it easier to remove dirt and keeps joints clean for a long time.

If daily maintenance is not carried out correctly it is possible to see opaque halos on the surface of the tiles, that the floor looks more glossy than it should or that footprints remain after walking. In these cases we suggest to apply a neat detergent such as Cleaner Pro and leave it for 5-10 minutes. Then rub with a cloth or a rug. Rinse thoroughly with water and collect the liquids with a rug or with a vacuum machine. Dry with a microfiber cloth.

Gigacer will never be held responsible for changes that might occur to the surface of the floor if it is cleaned with mechanical procedures and not with the products and procedures indicated in this guide.



INDICE DI STONALIZZAZIONE | SHADE VARIATION INDEX

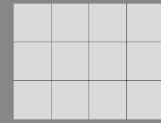

**V1 - LOW**  
**Prodotto monocromatico.**  
 Monochromatic product.

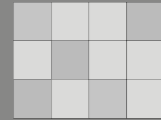

**V2 - MODERATE**  
**Prodotto con leggera variazione cromatica.**  
 Product with light chromatic variation.

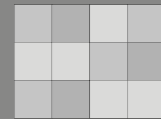

**V3 - HIGH**  
**Prodotto con marcata variazione cromatica.**  
 Product with high chromatic variation.

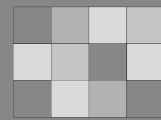

**V4 - VERY HIGH**  
**Prodotto con forte variazione cromatica.**  
 Product with very high chromatic variation.

Collezione Collection	Indice Index
Argilla	V2
Argilla Pentagon   PlayOne	V3
Concept 1 Mat   Levigato   Texture   Bocciardato	V2
Concept 1 Texture Platinum   Red   Flame   Turquoise	V3
Concept 1 PlayOne   Blend	V3
Concrete	V1
Concrete PlayOne	V2
Concrete / Made 2.0 Blend	V4
Déco	V4
Inclusioni	V3
Krea	V3
Krea PlayOne	V3
Light	V2
Light 250	V2
Made 2.0	V1
Quarry	V3
LCS1   LCS 2	V1
Béton gris 120x250   120x120	V2
Béton gris 60x120   30x120   60x60	V3
Béton blanc - All sizes	V1
Molitor 120x250   120x120	V2
Molitor 60x120   60x60	V3
Molitor 30x30	V4
Tokyo   All sizes	V1
Pontillé 120x250	V2
Pontillé other sizes	V4

CALIBRI | CALIBERS

Le nostre lastre sono sempre rettificate e hanno dimensioni finali in millimetri come da tabella.  
 Il calibro standard è lo 09 e i formati dello stesso calibro multipli tra loro sono modulari con 2mm di fuga.

Our slabs are always rectified and the table below indicates their final size in millimetres.  
 Our standard caliber is 09 and all sizes with the same caliber, when multiples, are modular with 2mm joint spacing.

Formato nominale (cm) Nominal size (cm)	Formato rettificato (mm) Rectified size (mm)	Calibro Caliber
120x250	1190x2500	09
60x250	594x2500	09
30x250	296x2500	09
10x250	97x2500	09
120x120	1190x1190	09
60x120	594x1190	09
30x120	296x1190	09
25x120	250x1190	09
60x60	594x594	09
30x60	296x594	09
30x30	296x296	09
15x60	147x594	09
10x60	97x594	09
5x60	47x594	09
20x20	197x197	09
15x30	147x296	09
15x15	147x147	09
15x15 Gigacer Shades	146x146	00
10x30	97x296	09
10x10	97x97	09

MODULARITÀ | MODULARITY





IMBALLI | PACKAGING

Spessore Thickness	Formato Size (cm)	Pallet (cm)	Pezzi x collo PCS/BX	M <sup>2</sup> x collo SQM/BX	Kg x collo KG/BX	Colli x pallet BX/PLT	M <sup>2</sup> x pallet SQM/PLT	Kg x pallet KG/PLT
24 mm	120x120	120x120	1	1,44	82,00	12	17,28	1010
	60x120	120x120	1	0,72	41,00	24	17,28	1010
	60x60	120x120	1	0,36	20,50	48	17,28	1010
12 mm through body	120x250 Unrectified	272x133x42h	1	3,00	84,00	12	36,00	1108
	120x250 Rectified	272x133x42h	1	3,00	84,00	12	36,00	1108
12 mm	120x120	120x120	1	1,44	40,30	36	51,84	1482
	60x120	120x120	2	1,44	40,30	36	51,84	1482
	60x60	120x120	3	1,08	30,20	48	51,84	1482
	30x60	120x120	4	0,72	20,20	72	51,84	1482
	30x30	120x120	10	0,90	25,20	40	36,00	1038
	15x60	80x120 euro	8	0,72	20,20	56	40,32	1161
	15x15	120x120	32	0,72	20,20	64	46,08	1322
	Large Pentagon	-	1	1,00	28,00	36	36,00	1048
	120x120 Quarry	120x120	1	1,44	40,30	36	51,84	1482
	60x120 Quarry	120x120	2	1,44	40,30	36	51,84	1482
	60x60 Quarry	120x120	2	0,72	20,10	72	51,84	1482
	30x60 Quarry	120x120	2	0,36	10,00	144	51,84	1482
	30x30 Quarry	120x120	2	0,18	5,00	288	51,84	1482
	Blend 5-10-15x60	-	12	0,72	20,20	48	34,56	999
	Brick Bar	80x120	12	0,54	14,00	40	2,16	599
	Mix Mosaic 3x3	80x120 euro	8	-	20,20	-	-	-
	Trail Mosaic 2x10	80x120 euro	8	-	20,20	-	-	-
	Battiscopa . Skirting 60x71	-	10	-	16,00	-	-	-
	Gradino costa retta Costa retta step 60x33x4	-	4	-	26,00	-	-	-
	Gradino costa retta Costa retta step 120x33x4	-	2	-	26,00	-	-	-
6 mm	120x250	272x133x42h	1	3,00	42,60	22	66,00	1038
	60x250	272x133x42h	1	1,50	21,00	44	66,00	1024
	30x250	272x133x42h	1	0,75	10,50	88	66,00	1025
	10x250	272x133x42h	1	0,25	4,20	56	14,00	335
	120x120	124x137	2	2,88	41,00	20	57,60	860
	60x120	124x137	4	2,88	40,80	24	69,12	1021
	60x120 LCS4	80x120 euro	2	1,44	20,40	30	43,20	642
	60x60	124x137	4	1,44	20,50	40	57,60	860
	30x120	124x137	4	1,44	20,50	48	69,12	1021

Spessore Thickness	Formato Size (cm)	Pallet (cm)	Pezzi x collo PCS/BX	M <sup>2</sup> x collo SQM/BX	Kg x collo KG/BX	Colli x pallet BX/PLT	M <sup>2</sup> x pallet SQM/PLT	Kg x pallet KG/PLT
6 mm	30x120 LCS1/LCS2	80x120 euro	2	0,72	10,20	60	43,20	645
	25x120 LCS3	80x120 euro	2	0,60	9,00	60	36,00	570
	30x60	124x137	8	1,44	20,50	48	69,12	1014
	15x60	80x120 euro	16	1,44	20,50	48	69,12	1021
	30x30	80x120 euro	20	1,80	25,60	40	72,00	1054
	15x30	80x120 euro	32	1,44	20,50	48	69,12	1021
	15x30 LCS2	80x120 euro	8	0,36	5,10	60	21,60	336
	10x30	80x120 euro	60	1,80	22,60	48	86,40	1084
	30x30 Mosaic	80x120 euro	10	0,90	13,00	60	54,00	810
	10x10	80x120 euro	50	0,50	8,00	64	32,00	512
	Large Pentagon	-	1	1,00	14,00	40	40,00	588
	Mosaic 30x30 (1,5x1,5)	-	10	-	10,00	-	-	-
	Wall Mosaic 30x30	-	10	-	13,00	-	-	-
	Stripes Mosaic 30x60	-	6	-	14,00	-	-	-
	Stripes Mosaic 15x120	-	4	-	9,00	-	-	-
	Action Mosaic 30x30 (4,4x5,2)	-	10	-	13,00	-	-	-
	Mosaic 30x30 (0,7x0,7)	-	10	-	8,50	-	-	-
	Button	-	22	0,02	0,25	-	-	-
	Small	-	44	0,36	4,60	-	-	-
	Brick	-	22	0,36	4,60	-	-	-
	Plate	-	22	0,60	7,70	-	-	-
	Triangle	-	18	0,24	3,25	-	-	-
	Diamond	-	9	0,24	3,25	-	-	-
	Octagon (Button included)	-	20	1,80	25,00	-	-	-
	Small Pentagon	-	24	0,96	13,50	-	-	-
	Small Hexagon	-	11	0,23	3,00	-	-	-
	Large Hexagon	-	14	1,18	15,00	-	-	-
Battiscopa . Skirting 120x71	-	8	-	8,00	-	-	-	
Gradino costa retta Costa retta step 60x33x4	-	4	-	26,00	-	-	-	
Gradino costa retta Costa retta step 120x33x4	-	2	-	26,00	-	-	-	
6/12 mm	Blend 5-10-15x60	-	18	1,08	12,00	48	51,84	588



IMBALLI | PACKAGING

Spessore Thickness	Formato Size (cm)	Pallet (cm)	Pezzi x collo PCS/BX	M <sup>2</sup> x collo SQM/BX	Kg x collo KG/BX	Colli x pallet BX/PLT	M <sup>2</sup> x pallet SQM/PLT	Kg x pallet KG/PLT
4.8 mm	120x120	124x137	2	2,88	34,60	23	66,24	835
	60x120	124x137	4	2,88	34,60	24	69,12	870
	60x60	124x137	5	1,80	21,60	40	72,00	904
	30x60	124x137	10	1,80	21,60	48	86,40	1067
	15x60	80x120 euro	16	1,44	19,00	48	69,12	940
	30x30	80x120 euro	22	1,98	23,70	40	79,20	980
	20x20	80x120 euro	20	0,80	10,45	60	48,00	655
	15x15	80x120 euro	22	0,50	5,90	112	55,44	690
	Blend 5-10-15x60	-	24	1,44	17,30	48	69,12	860
	Mosaic 30x30 (1,5x1,5)	-	10	-	10,00	-	-	-
	Wall Mosaic 30x30	-	10	-	9,00	-	-	-
	Stripes Mosaic 30x60	-	6	-	11,00	-	-	-
	Stripes Mosaic 15x120	-	4	-	7,00	-	-	-
	Action Mosaic 30x30 (4,4x5,2)	-	10	-	9,00	-	-	-
	Mosaic 30x30 (0,7x0,7)	-	10	-	7,00	-	-	-
	Button	-	22	0,02	0,25	-	-	-
	Small	-	44	0,36	4,60	-	-	-
	Brick	-	22	0,36	4,60	-	-	-
	Plate	-	22	0,60	7,70	-	-	-
	Triangle	-	18	0,24	3,25	-	-	-
Diamond	-	9	0,24	3,25	-	-	-	
Octagon (Button included)	-	22	1,98	23,70	-	-	-	
Small Pentagon	-	24	0,96	13,50	-	-	-	
Small Hexagon	-	11	0,23	3,00	-	-	-	
Large Hexagon	-	14	1,18	15,00	-	-	-	
Battiscopa . Skirting 120x71	-	8	-	11,00	-	-	-	





CARATTERISTICHE TECNICHE | TECHNICAL SPECIFICATIONS

LASTRE DI GRES PORCELLANATO   PORCELAIN SLABS - ISO 13006 - G - Bia UGL (E ≤ 0,5%) UNI EN 14411 - G -					
	CARATTERISTICHE TECNICHE TECHNICAL SPECIFICATIONS	NORMA ISO STANDARD	SPESSORE THICKNESS	VALORI PRESCRITTI DALLE NORME INTERNATIONAL STANDARDS	VALORE MEDIO GIGACER AVERAGE GIGACER VALUE
	CARATTERISTICHE DIMENSIONALI DIMENSIONAL CHARACTERISTICS	ISO 10545-2	-	S > 410	
	LATI SIDES		-	± 0,6%	± 0,2%
	SPESSORE THICKNESS		-	± 5%	± 3%
	RETTILINEITÀ DEGLI SPIGOLI STRAIGHTNESS OF EDGES		-	± 0,5%	± 0,2%
	ORTOGONALITÀ RECTANGULARITY		-	± 0,6%	± 0,2%
	PLANARITÀ SURFACE FLATNESS	-	-	± 0,5%	± 0,2%
	ASSORBIMENTO D'ACQUA WATER ABSORPTION	ISO 10545-3	-	++ ≤ 0,5%	≤ 0,1%
	RESISTENZA ALLA FLESSIONE BENDING STRENGTH	ISO 10545-4	≠ 4.8 mm	≥ 35N/mm <sup>2</sup>	≥ 40 N/mm <sup>2</sup>
			≠ 6 mm	≥ 35N/mm <sup>2</sup>	≥ 40 N/mm <sup>2</sup>
			≠ 12 mm	≥ 35N/mm <sup>2</sup>	≥ 40 N/mm <sup>2</sup>
			≠ 24 mm	≥ 35N/mm <sup>2</sup>	≥ 52 N/mm <sup>2</sup> **
	MODULO DI ROTTURA MODULUS OF RUPTURE	ISO 10545-4	≠ 4.8 mm	> 700N (sp. < 7,5mm)	> 700 N
			≠ 6 mm	> 700N (sp. < 7,5mm)	> 700 N
			≠ 12 mm	> 1.300N (sp. ≥ 7,5mm)	≥ 4000 N
			≠ 24 mm	> 1.300N (sp. ≥ 7,5mm)	≥ 20000 N**
	RESISTENZA ALL'ABRASIONE PROFONDA RESISTANCE TO DEEP ABRASION	ISO 10545-6	-	≤ 175mm <sup>3</sup>	≤ 145 mm <sup>3</sup>
	COEFFICIENTE DI DILATAZIONE TERMICA LINEARE COEFFICIENT OF LINEAR THERMAL EXPANSION	ISO 10545-8	-	≤ 9x10 6°c 1	≤ 7x10 6°c 1
	RESISTENZA AGLI SBALZI TERMICI RESISTANCE TO THERMAL SHOCKS	-	-	METODO DISPONIBILE AVAILABLE METHOD	RESISTE RESISTANT
	RESISTENZA AL GELO FROST RESISTANCE	ISO 10545-12	-	METODO DISPONIBILE AVAILABLE METHOD	RESISTE RESISTANT
	RESISTENZA ALL'ATTACCO CHIMICO RESISTANCE TO CHEMICAL ATTACKS	ISO 10545-13	-	min. UB	RESISTE RESISTANT
	RESISTENZA ALLE MACCHIE STAIN RESISTANCE	ISO 10545-14	-	METODO DISPONIBILE AVAILABLE METHOD	RESISTE RESISTANT
	RESISTENZA AI PRODOTTI DI PULIZIA ANTICOVID ANTICOVID CLEANING PRODUCTS RESISTANCE	-	-	-	RESISTE RESISTANT

\* Valore medio. Average value.

\*\*Dato ottenuto su formato 30x30cm. Measurements made on the 30x30 cm format.

Trattandosi di un prodotto tecnico a solo impasto senza smalto alcune impurità e puntinature visibili nei colori chiari sono da considerarsi una caratteristica tecnica del prodotto. We produce technical unglazed porcelain stoneware slabs, and some light impurities and dots must be considered as a standard feature of the product.

COEFFICIENTE DI ATTRITO | COEFFICIENT OF FRICTION

LASTRE DI GRES PORCELLANATO   PORCELAIN SLABS - ISO 13006 - G - BIA UGL (E ≤ 0,5%) UNI EN 14411 - G -													
	SUPERFICI SURFACES		SPESSORE THICKNESS	DIN 51130	DIN 51097	BCR	BRITISH PENDULUM BS7976	R9729 UPI/ EMPA	DCOF (SECTION 9.6 ANSI A 137.1.2012)				
	COEFFICIENTE D'ATTRITO COEFFICIENT OF FRICTION	BETON		≠ 6mm ≠ 12mm	-	-	> 0,40	-	GS1	> 0,42 wet			
		MOLITOR		≠ 6mm	R10*	-	> 0,40	-	GS1	> 0,42 wet			
		TOKYO		≠ 12mm ≠ 24mm	R10	A + B	> 0,40	> 36 WET	GS2/GB1	> 0,42 wet			
		ARGILLA MATERIAL		≠ 6mm	R10	A	> 0,40	-	GS1	> 0,42 wet			
		CONCEPT 1	MAT		≠ 6mm ≠ 12mm ≠ 24mm	R10	-	-	> 36 WET	GS1	-		
			TEXTURE MAT		≠ 6mm	R10	A	-	-	-	-		
			BOCCIARDATO		≠ 12mm ≠ 24mm	R10	A + B	> 0,40	> 36 WET	GS2/GB1	> 0,42 wet		
			BOCCIARDATO ANTISLIP		≠ 12mm ≠ 24mm	R11	A + B + C	> 0,40	> 36 WET	GS2/GB1	> 0,42 wet		
		CONCRETE	KREA		≠ 4.8mm	R10	A + B*	> 0,40	-	GS1	-		
					≠ 6mm	R10	A + B*	> 0,40	-	GS1	-		
					≠ 12mm ≠ 24mm	R10	A + B	> 0,40	> 36 WET except for ice colour	GS2/GB1	> 0,42 wet		
		INCLUSIONI	EXTRAFINE	MAT		≠ 6mm	R10	A	> 0,40	-	GS1	> 0,42 wet	
				SOAVE		MAT		≠ 12mm ≠ 24mm	R10	A + B*	> 0,40	> 36 WET	GS2/GB1
					BOCCIARDATO		≠ 12mm ≠ 24mm	R10	A + B	> 0,40	> 36 WET	GS2/GB1	> 0,42 wet
					BOCCIARDATO ANTISLIP		≠ 12mm ≠ 24mm	R11	A + B + C	> 0,40	> 36 WET	GS2/GB1	> 0,42 wet
		LIGHT	KREA		≠ 4.8mm ≠ 6mm	R10	A + B*	> 0,40	-	GS1	-		
					≠ 12mm ≠ 24mm	R10	A + B	> 0,40	> 36 WET	GS2/GB1	> 0,42 wet		
			CRESPO			R10	A + B	> 0,40	-	GS1	-		
			RIGATO			R9	A	> 0,40	-	GS1	-		
ROCCIA			≠ 6mm	R9	A	> 0,40	-	GS1	-				
SCOLPITO				R10	A + B	> 0,40	-	GS1	-				
MADE 2.0	GESSO			R9	A	> 0,40	-	GS1	-				
	GESSO		≠ 12mm	R9	A	> 0,40	-	GS1	-				
	MAT		≠ 12mm ≠ 24mm	R10	-	> 0,40	> 36 WET except for ice colour	GS2/GB1	> 0,42 wet				
	BOCCIARDATO ANTISLIP		≠ 12mm ≠ 24mm	R11	A + B + C	> 0,40	> 36 WET	GS3/GB2	> 0,42 wet				
QUARRY	MAT		≠ 6mm ≠ 12mm ≠ 24mm	R10	A+B	> 0,40	> 36 WET	GS2/GB1	> 0,42 wet				
	BOCCIARDATO ANTISLIP		≠ 12mm ≠ 24mm	R11	A+B+C	> 0,40	> 36 WET	GS2/GB1	> 0,42 wet				

I valori di resistenza allo scivolamento, coefficiente di attrito statico e dinamico, riportati sul catalogo e sul sito, sono da ritenersi puramente indicativi e non vincolanti. Ogni eventuale specifica necessità dovrà essere da noi confermata al momento dell'ordine e comunque sempre prima della posa. The values of slip resistance and of static and dynamic friction coefficient shown in the catalogue, and in the web site are merely indicative and non-binding. Any possible specific requirement must be confirmed by us at the order and anyway always before the installation.



## CERTIFICAZIONI | CERTIFICATIONS

GIGACER ha conseguito le certificazioni di processo ISO 9001:2015 e ISO 14001:2015.

Gigacer ha conseguito le certificazioni UNI EN 14411:2012.

La qualità dei prodotti Gigacer viene controllata costantemente tramite test effettuati dai principali laboratori ed enti di certificazione internazionali.

L'ultima certificazione ottenuta, in ordine di tempo, è la QB-UPEC per alcune superfici, con risultati brillanti.

E' possibile scaricare la lista completa dei prodotti Gigacer che hanno ottenuto la certificazione QB-UPEC, completa di valori, al seguente url: [www.cstb.fr](http://www.cstb.fr)

Gigacer has achieved the process certifications ISO 9001:2015 e ISO 14001:2015.

Gigacer has achieved the process certifications UNI EN 14411:2012.

The quality of Gigacer products is constantly monitored with tests made by the main international certification laboratories.

The last certification achieved is the QB-UPEC in some surfaces, with brilliant results.

It is possible to download the list of Gigacer products that obtained QB-UPEC certification with all the values at the following url: [www.cstb.fr](http://www.cstb.fr)



**Non si danneggia con i detergenti chimici anticovid.**

Does not damage with chemical detergents anticovid.

---

Photo credits: ©FLC, FLC/ADAGP, FLC/Prolitteris 2014 - Reproductions of the works and portraits of Le Corbusier: © FLC/ADAGP

---

**Quanto contenuto nel catalogo è puramente indicativo riguardo a colori e decorazioni.**

Real colors and decorations might slightly differ from those depicted in this catalogue.

---

**Pubblicato da**

Published by

**Gigacer S.p.A.**

Via Caltagirone, 72

48018 Faenza (RA) ITALY

T: +390546637111

F: +390546637127

[www.gigacer.it](http://www.gigacer.it)

[info@gigacer.it](mailto:info@gigacer.it)







GIGACER

**GIGACER S.P.A.**

Via Caltagirone, n.72 - 48018 Faenza (RA) ITALY  
Tel. +39 0546 637 111 - Fax +39 0546 637 127  
info@gigacer.it - www.gigacer.it

