

Unigestone

5 COLOURS

5 SIZES

3 SURFACES

A collection inspired by the aesthetics of different stones, granites and marbles, skilfully mixed together liven up the style of every environment, whether residential or commercial.

Una collezione ispirata all'estetica di pietre, graniti e marmi differenti sapientemente miscelati tra di loro per muovere con carattere lo stile di ogni ambiente, residenziale o commerciale.

Eine am aussehen verschiedener und auf gelungene Weise miteinander kombinierter Steine, Granite und Marmorarten inspirierte Kollektion. Bringt stilvoll Bewegung und Charakter in jeden Gewerbe- oder Wohnraum.

Une collection qui puise son inspiration a l'esthétique de la pierre. Plusieurs types de granits et de marbres savamment mélangés apportent une note authentique de caractère à tout espace de vie, à usage privé ou commercial.

Unigestone

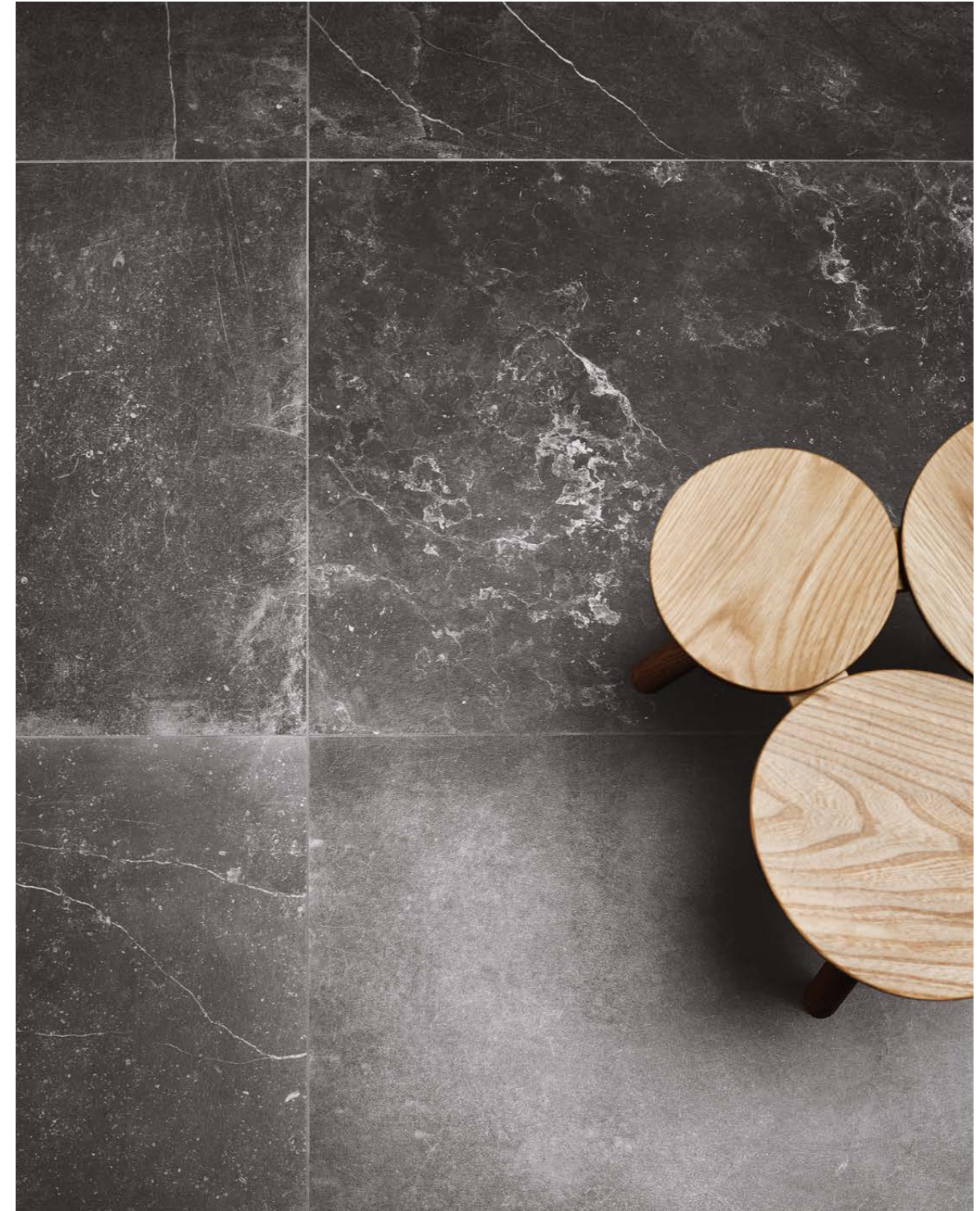

Spazi Residenziali
Residential Spaces

P. 5

Spazi Pubblici
Public Areas

P. 21

Informazioni Tecniche
Technical Information

P. 37

La superficie della materia è caratterizzata da uno stonalizzo grafico ben bilanciato da un tono di fondo morbido ed omogeneo per un risultato finale molto equilibrato nella sua variabilità. Disponibile in cinque varianti cromatiche in finitura naturale e levigata è ideale per rivestire ambienti interni ed esterni ad alto impatto emozionale.

The material surface is characterized by well-balanced graphic colour and by a soft and uniform colour background for an end result which is very stable in its variability. Available in five different colours in natural and polished finish, it is perfect for covering interior and outdoor environments with high emotional impact.

Die Oberfläche des Materials ist durch grafische Nuancierungen geprägt, die durch eine weiche und gleichmässige Grundnote ausgeglichen werden. Das sorgt für einen trotz der Variabilität harmonischen Gesamteindruck. In fünf Farbvarianten jeweils mit Oberfläche natur und Poliert erhältlich. Ideal zur Verkleidung von Innen- und Außenbereichen von hoher Emotionaler Wirkung.

La surface de la matière est caractérisée par un dénuancement graphique bien équilibré, sur un fond au ton doux et homogène, pour aboutir à une variabilité parfaitement maîtrisée. Disponible en cinq variantes chromatiques, finition naturelle et polie, c'est un revêtement idéal pour l'intérieur et l'extérieur à fort impact émotionnel.

Spazi Residenziali

Residential Spaces
Wohnanlagen
Espaces Résidentiels

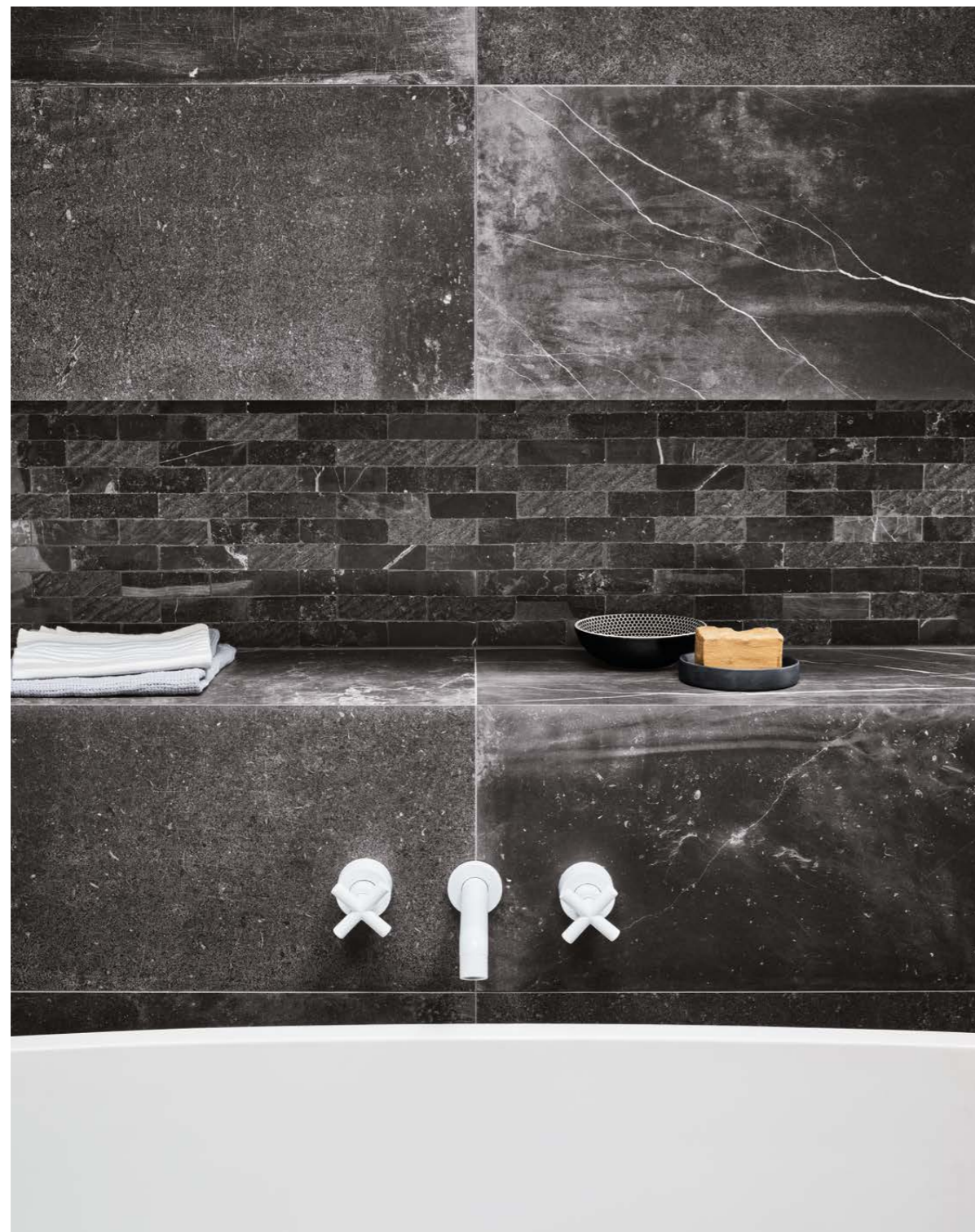

COLORI / COLOURS

AMBIENTI / AMBIENT

PAGINA / PAGE

Nite	Bathroom	6
Titanium	Bedroom	10
Sand	Kitchen	14
Silver	Entrance	17
Silk	Living	18

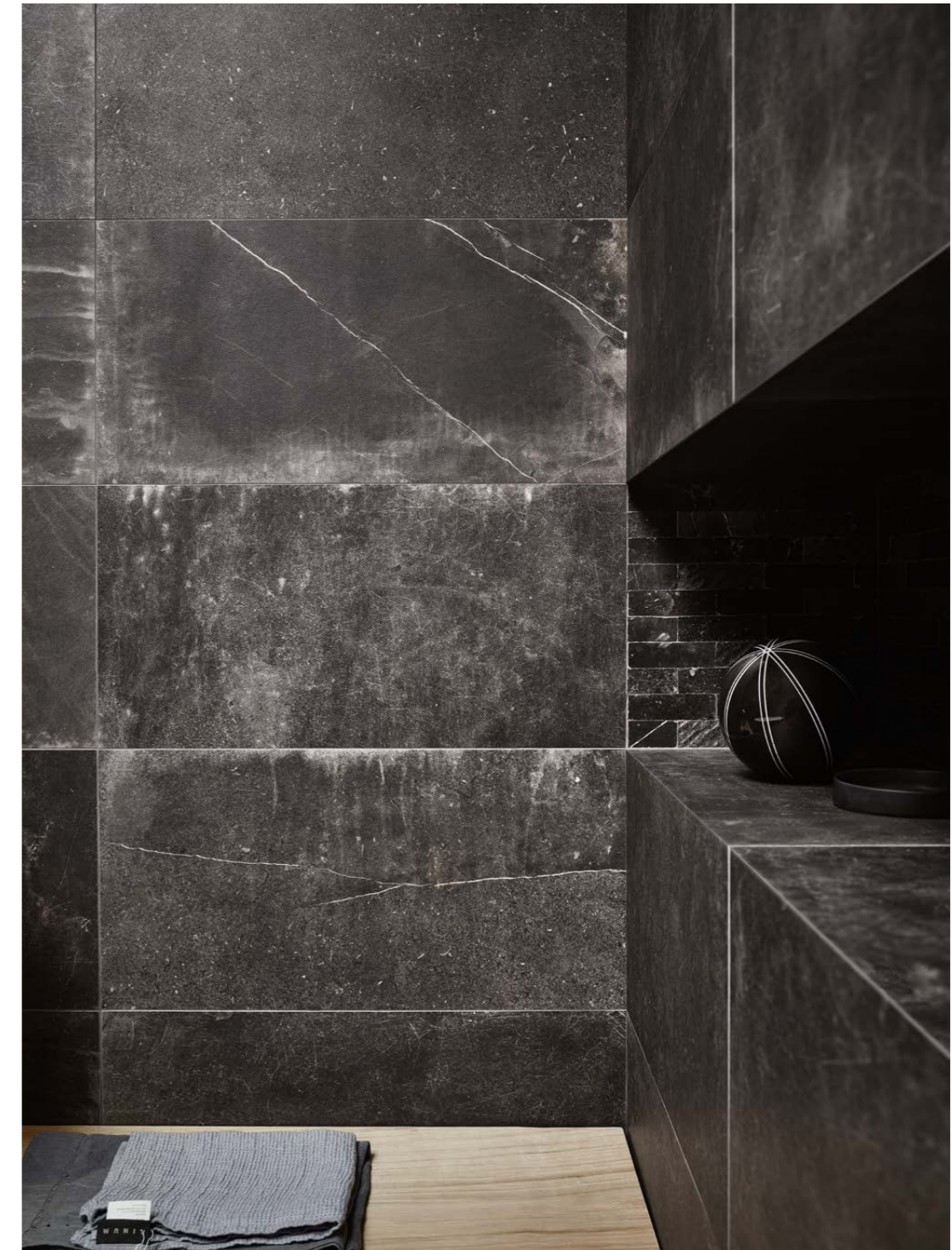









Silver

The result is a tile which, depending on how it is interpreted, can be used in environments characterised by various styles, from classic to contemporary and eclectic.

Ein Erzeugnis, das je nach Auslegung für verschiedene Stilarten von Klassik bis Modern bis hin zum Eklektizismus geeignet ist.

En fonction de l'interprétation qu'on lui donne, ce produit pourra être décliné sur une grande variété de styles, du classique au contemporain en passant par l'éclectique.

Un prodotto che a seconda dell'interpretazione può essere declinato in varie tipologie di stile, dal classico al contemporaneo, all'eclettico.

30x60 - 12"x24" Naturale Rettificato





Spazi Pubblici

Public Areas
Öffentliche Räumlichkeiten
Espaces Publics



COLORI / COLOURS

AMBIENTI / AMBIENT

PAGINA / PAGE

Silk	Shop	22
Sand	Hall	27
Silver	Airport Lounge	28
Titanium	Boutique Hotel	32
Nite	Restaurant	34

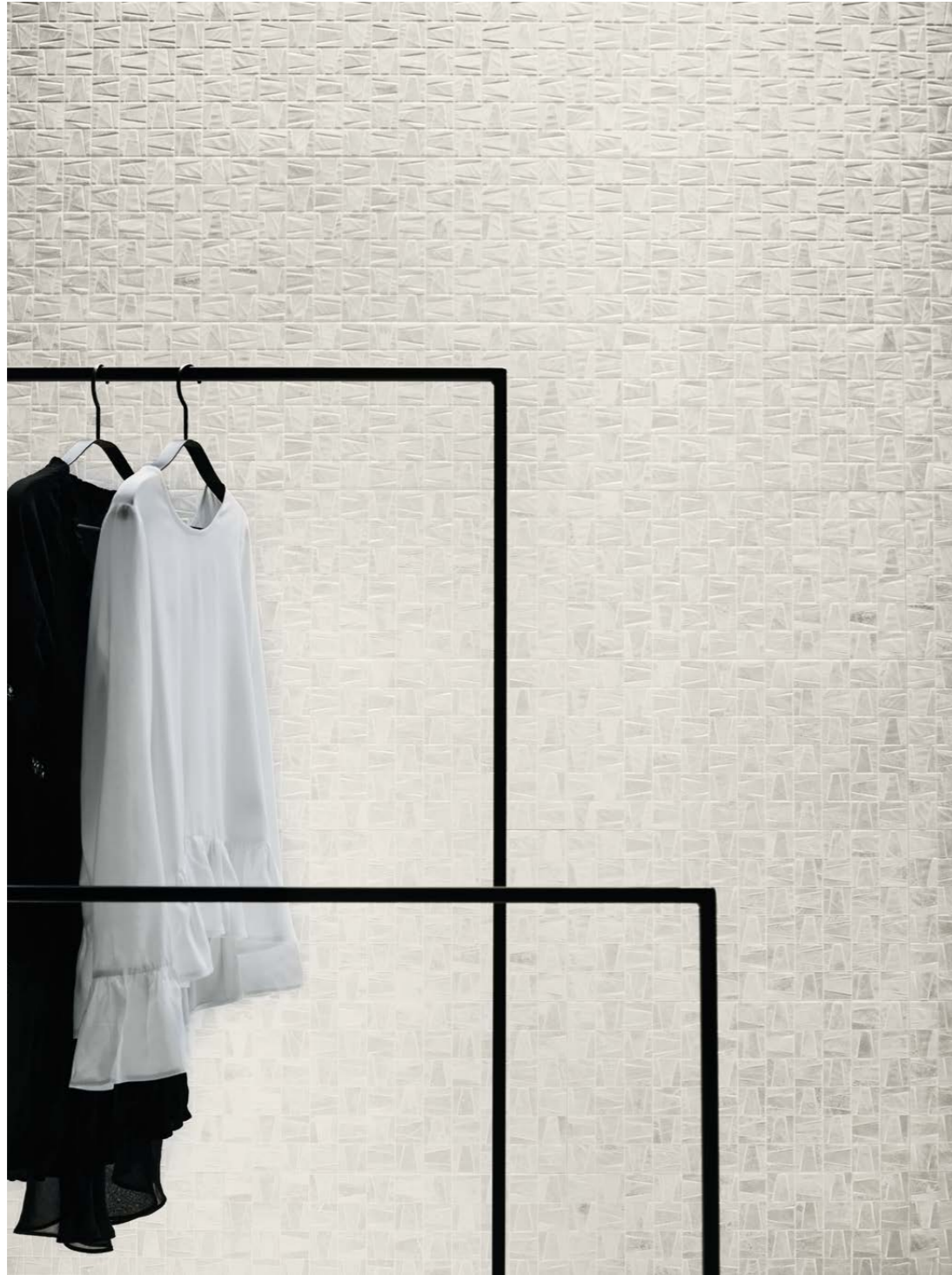



Sand

It is extremely “transversal”, thanks to its flexibility and the fact that it can be matched and paired with materials of different kinds, “adaptable” due to the possibilities it offers when it comes to interpreting different styles and “versatile” as it can be used to meet a wide variety of design requirements.

Sehr “zweckübergreifend” dank seiner Vielseitigkeit, Kombinationen und Zusammenstellungen mit verschiedenartigen Materialien; “mannigfaltig”, weil es sich mit unterschiedlichen Stilen interpretieren lässt; “vielseitig” für die jeweiligen Entwurfsbedürfnisse.

Sa polyvalence le rend vraiment “transversal”; il peut être associé à des matériaux de nature différente, s’adapte à des styles divers et se plie aux contraintes de la conception.

Altamente “trasversale”, grazie alla sua flessibilità, abbinamenti e accostamenti con materiali di natura differente, “duttile” per la possibilità che offre di interpretazione con stili differenti, “versatile” alle differenti necessità di progettazione.

80×80 - 31½”×31½” Levigato Rettificato







Titanium

It is an intrinsically sustainable material yet at the same time flaunts a highly sophisticated charm thanks to the technology used to create it.

Das Material ist dank seiner Beschaffenheit nachhaltig und seiner Fertigungstechnologie gleichzeitig auch reich an ausgefeilter Eleganz.

De par sa nature, c'est un matériel écologique qui possède néanmoins un charme très sophistiqué dû à la technologie adoptée pour sa réalisation.

Un materiale sostenibile per la sua stessa natura ed al contempo ricco di un fascino altamente sofisticato grazie alla tecnologia utilizzata per la sua realizzazione.

60x60 - 24"x24" Naturale Rettificato



Uniquestone
Public Areas

Nite

Unigestone is the result of ongoing research and experimentation process. This has generated a product that closely resembles the spontaneous, irregular graphic look of the natural materials to which it is inspired.

Unigestone ist das Ergebnis ständiger Recherchen und Versuche, die ein Produkt hervorbrachten, das eine große Ähnlichkeit mit dem spontanen, ungleichmäßigen Aussehen der natürlichen Materialien hat, an denen es inspiriert ist.

Unigestone est le fruit d'une recherche ininterrompue. Celle-ci a donné vie à un produit très proche de la représentation graphique, spontanée et irrégulière, des matériaux naturels dont il s'inspire.

Unigestone è il frutto di una ricerca di continua sperimentazione che ha generato un prodotto molto vicino alla spontanea ed irregolare rappresentazione grafica dei materiali naturali cui si ispira.

80x80 - 31½"x31½" Levigato Rettificato



Unigestone
Public Areas

Informazioni Tecniche

5

Colori
Colours
Farben
Couleurs



5

Formati
Sizes
Formate
Formats

*60×119,5 80×80 *60×60 *30×60 *10×53
24"×47½" 31½"×31½" 24"×24" 12"×24" 4"×20"



*Attenzione: verificare in fase di ordine il codice e l'imballo / Note: In the ordering phase please check code and packaging /
Bitteachten: Beim Bestellen bitte die Kodenummer und die Verpackung kontrollieren / Attention : Merci de vérifier emballage et la référence au moment de la commande

1

Spessori
Thickness
Stärke
Epaisseur

±9,5

3

Superfici
Surfaces
Oberflächen
Surfaces

Naturale Levigato Bocciardato

3

Strutture 3D
3D structures
Strukturen
Décorations en relief



i

Effetto Pietra
Stone Look
Natursteinoptik
Effet Pierre

Rivestimento
Wall Tiles
Wandfliesen
Revêtement

Pavimento
Floor Tiles
Bodenfliesen
Sol

Gres fine porcellanato ad impasto colorato
Coloured-body fine porcelain stoneware
Feinsteinzeug aus farbiger Masse
Grès cérame fin à pâte colorée

Tecnologia digitale
Digital technology
Digital technologie
Technologie numérique



Silk



60×119,5 - 24"×47 1/2"
02995 | Unique Silk Nat/Ret U4 P3 E3 C2
02999 | Unique Silk Lev/Ret
03003 | Unique Silk Bocciardato Ret



80×80 - 31 1/2"×31 1/2"
03639 | Unique Silk Nat/Ret U4 P3 E3 C2
03641 | Unique Silk Lev/Ret



60×60 - 24"×24"
01702 | Unique Silk Nat/Ret U4 P4 E3 C2
01691 | Unique Silk Lev/Ret



60×119,5 - 24"×47 1/2"
03008 | Unique Silk Level Ret



30×60 - 12"×24"
01707 | Unique Silk Nat/Ret U4 P3 E3 C2
01696 | Unique Silk Lev/Ret

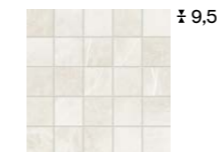

30×30 - 12"×12"
01771 | Unique Silk Mosaico Nat/Ret



10×53 - 4"×20"
01792 | Unique Silk Chevron Nat/Ret U4 P3 E3 C2

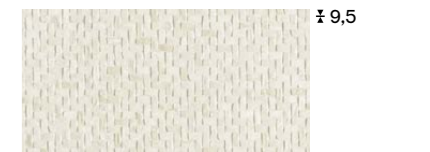

30×60 - 12"×24"
01918 | Unique Weave Sk/Sd Nat/Ret



30×30 - 12"×12"
01786 | Unique Silk Mix All In Ret



30×60 - 12"×24"
01785 | Unique Nite Maya Design Ret



30×60 - 12"×24"
01781 | Unique Silk Maya Ret



Gres fine porcellanato ad impasto colorato
Tecnologia Digitale

Coloured-body fine porcelain stoneware
Digital Technology

Feinsteinzeug aus farbiger Masse
Digital Technologie

Grès cérame fin à pâte colorée
Technologie Numérique

Sand



± 9,5

60×119,5 - 24"×47½"
02996 | Unique Sand Nat/Ret
03000 | Unique Sand Lev/Ret
03004 | Unique Sand Bocciardato Ret

U4 P3 E3 C2



± 9,5

80×80 - 31½"×31½"
03684 | Unique Sand Nat/Ret
03867 | Unique Sand Lev/Ret

U4 P3 E3 C2

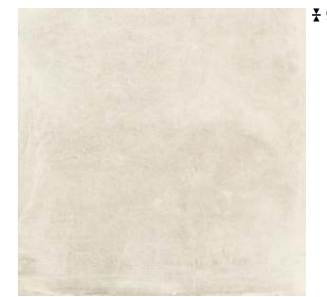

± 9,5

60×60 - 24"×24"
01703 | Unique Sand Nat/Ret
01692 | Unique Sand Lev/Ret

U4 P4 E3 C2



± 9,5

60×119,5 - 24"×47½"
03009 | Unique Sand Level Ret



± 9,5

30×60 - 12"×24"
01708 | Unique Sand Nat/Ret
01697 | Unique Sand Lev/Ret

U4 P3 E3 C2

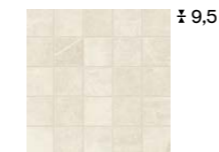

± 9,5

30×30 - 12"×12"
01772 | Unique Sand Mosaico Nat/Ret



± 9,5

10×53 - 4"×20"
01793 | Unique Sand Chevron Nat/Ret

U4 P3 E3 C2



± 9,5

30×60 - 12"×24"
01918 | Unique Weave Sk/Sd Nat/Ret



± 9,5

30×30 - 12"×12"
01787 | Unique Sand Mix All In Ret



± 9,5

30×60 - 12"×24"
01782 | Unique Sand Maya Ret

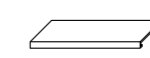
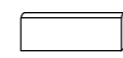



Silver



± 9,5

60×119,5 - 24"×47½"

02997 | Unique Silver Nat/Ret
03001 | Unique Silver Lev/Ret
03005 | Unique Silver Bocciardato Ret

U4 P3 E3 C2



± 9,5

80×80 - 31½"×31½"

03642 | Unique Silver Nat/Ret
03643 | Unique Silver Lev/Ret

U4 P3 E3 C2



± 9,5

60×60 - 24"×24"

01704 | Unique Silver Nat/Ret
01693 | Unique Silver Lev/Ret

U4 P4 E3 C2



± 9,5

60×119,5 - 24"×47½"

03010 | Unique Silver Level Ret



± 9,5

30×60 - 12"×24"

01709 | Unique Silver Nat/Ret
01698 | Unique Silver Lev/Ret

U4 P3 E3 C2



± 9,5

30×30 - 12"×12"

01773 | Unique Silver Mosaico Nat/Ret



± 9,5

10×53 - 4"×20"

01794 | Unique Silver Chevron Nat/Ret

U4 P3 E3 C2



± 9,5

30×60 - 12"×24"

01917 | Unique Weave Tm/Sr Nat/Ret



± 9,5

30×30 - 12"×12"

01788 | Unique Silver Mix All In Ret



± 9,5

30×60 - 12"×24"

01785 | Unique Nite Maya Design Ret

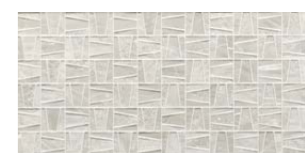

± 9,5

30×60 - 12"×24"

01783 | Unique Silver Maya Ret

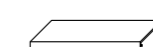
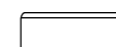



Titanium



± 9,5

60×119,5 - 24"×47½"

02976 | Unique Titanium Nat/Ret
02977 | Unique Titanium Lev/Ret
03006 | Unique Titanium Bocciardato Ret

U4 P3 E3 C2



± 9,5

80×80 - 31½"×31½"

03637 | Unique Titanium Nat/Ret U4 P3 E3 C2
03638 | Unique Titanium Lev/Ret



± 9,5

60×60 - 24"×24"

01705 | Unique Titanium Nat/Ret U4 P4 E3 C2
01694 | Unique Titanium Lev/Ret



± 9,5

60×119,5 - 24"×47½"

03011 | Unique Titanium Level Ret



± 9,5

30×60 - 12"×24"

01711 | Unique Titanium Nat/Ret U4 P3 E3 C2
01699 | Unique Titanium Lev/Ret



± 9,5

30×30 - 12"×12"

01774 | Unique Titanium Mosaico Nat/Ret



± 9,5

10×53 - 4"×20"

01795 | Unique Titanium Chevron Nat/Ret U4 P3 E3 C2



± 9,5

30×60 - 12"×24"

01917 | Unique Weave Tm/Sr Nat/Ret



± 9,5

30×30 - 12"×12"

01789 | Unique Titanium Mix All In Ret



± 9,5

30×60 - 12"×24"

01785 | Unique Nite Maya Design Ret



± 9,5

30×60 - 12"×24"

01784 | Unique Titanium Maya Ret

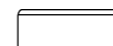



Gres fine porcellanato ad impasto colorato
Tecnologia Digitale

Coloured-body fine porcelain stoneware
Digital Technology

Feinsteinzeug aus farbiger Masse
Digital Technologie

Grès cérame fin à pâte colorée
Technologie Numérique

Nite



60×119,5 - 24"×47½"
02998 | Unique Nite Nat/Ret U4 P3 E3 C2
03002 | Unique Nite Lev/Ret
03007 | Unique Nite Bocciardato Ret

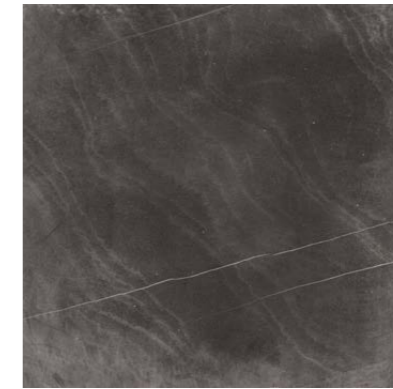

80×80 - 31½"×31½"
03617 | Unique Nite Nat/Ret U4 P3 E3 C2
03618 | Unique Nite Lev/Ret

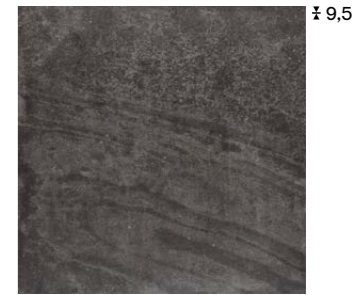

60×60 - 24"×24"
01706 | Unique Nite Nat/Ret U4 P4 E3 C2
01695 | Unique Nite Lev/Ret



60×119,5 - 24"×47½"
03012 | Unique Nite Level Ret



30×60 - 12"×24"
01712 | Unique Nite Nat/Ret U4 P3 E3 C2
01701 | Unique Nite Lev/Ret

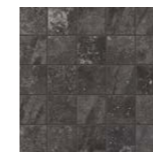

30×30 - 12"×12"
01775 | Unique Nite Mosaico Nat/Ret



10×53 - 4"×20"
01796 | Unique Nite Chevron Nat/Ret U4 P3 E3 C2



30×30 - 12"×12"
01791 | Unique Nite Mix All In Ret



30×60 - 12"×24"
01785 | Unique Nite Maya Design Ret

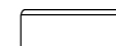

Riepilogo Gamma

Collection
Serie
Gamme

Formati Sizes									Strutture 3D 3D Structures			
	*60*119,5 24"*47½"	80*80 31½"*31½"	*60*60 24"*24"	*30*60 12"*24"	Chevron *10*53 - 4"*20"	DIN 51130	DIN 51097	DCOF	Level *60*119,5 - 24"*47½"	Maya *30*60 12"*24"	Weave *30*60 12"*24"	
	± 9,5	± 9,5	± 9,5	± 9,5	± 9,5				± 9,5	± 9,5	± 9,5	
 Silk	Nat/Ret	02995	03639	01702	01707	01792	R10	A+B	>0.42	03008	01781	01918
	Lev/Ret	02999	03641	01691	01696		V3					
	Bocciardato	03003					R11	A+B+C	>0.42			
 Sand	Nat/Ret	02996	03684	01703	01708	01793	R10	A+B	>0.42	03009	01782	01918
	Lev/Ret	03000	03867	01692	01697		V3					
	Bocciardato	03004					R11	A+B+C	>0.42			
 Silver	Nat/Ret	02997	03642	01704	01709	01794	R10	A+B	>0.42	03010	01783	01917
	Lev/Ret	03301	03643	01693	01698		V3					
	Bocciardato	03005					R11	A+B+C	>0.42			
 Titanium	Nat/Ret	02976	03637	01705	01711	01795	R10	A+B	>0.42	03011	01784	01917
	Lev/Ret	02977	03638	01694	01699		V3					
	Bocciardato	03006					R11	A+B+C	>0.42			
 Nite	Nat/Ret	02998	03617	01706	01712	01796	R10	A+B	>0.42	03012	01785	
	Lev/Ret	03002	03618	01695	01701		V3					
	Bocciardato	03307					R11	A+B+C	>0.42			

*Attenzione: verificare in fase di ordine il codice e l'imballo
 *Note: In the ordering phase please check code and packaging
 *Bitteachten: Beim Bestellen bitte die Kodenummer und die Verpackung kontrollieren
 *Attention : Merci de vérifier emballage et la référence au moment de la commande







Riepilogo Gamma

Collection
Serie
Gamme

Formati Sizes			Pezzi Speciali Special Pieces			
	Mosaico *30*30 - 12"*12"	Mosaico Mix All In *30*30 - 12"*12"	Gradino Costa Retta 33*119,5 - 13"*47½"	Battiscopa 6,5*120 - 2½"*48"	Battiscopa 8*80 - 3½"*31½"	Battiscopa 8*60 - 3½"*24"
	± 9,5	± 9,5	± 9,5	± 10,5	± 10,5	± 9,5
 Silk	Nat/Ret	01771	03733	01797	01808	01819
	Lev/Ret		01786	01803	01814	01825
 Sand	Nat/Ret	01772	03734	01798	01809	01821
	Lev/Ret		01787	01804	01815	01826
 Silver	Nat/Ret	01773	03735	01799	01811	01822
	Lev/Ret		01788	01805	01816	01827
 Titanium	Nat/Ret	01774	03736	01801	01812	01823
	Lev/Ret		01789	01806	01817	01828
 Nite	Nat/Ret	01775	03737	01802	01813	01824
	Lev/Ret		01791	01807	01818	01829

*Attenzione: verificare in fase di ordine il codice e l'imballo
 *Note: In the ordering phase please check code and packaging
 *Bitteachten: Beim Bestellen bitte die Kodenummer und die Verpackung kontrollieren
 *Attention : Merci de vérifier emballage et la référence au moment de la commande

Packing
Verpackung
Emballage

Formati Sizes		± MM	 Pezzi Scatola Pieces/Box Stck/Karton Carreaux/Boîte	 Mq/Scatola Sqmt/Box Qm/Karton M2/Boîte	 Kg/Scatola Kgs/Box Kg/Karton Kg/Boîte	 Scatole/Paletta Boxes/Pallet Karton/Palette Boîte/Palette	 Mq/Paletta Sqmt/Pallet Qm/Pallet M2/Palette	 Kg/Paletta Kgs/Pallet Kg/Pallet Kg/Palette	 Formato Paletta Size Pallet Format Pallet Dim. Palette
*60*119,5 (24"*47½") Nat/Ret*	P	9,5	2	1,434	31,00	30	43,02	930	120*80*75
*60*119,5 (24"*47½") Lev/Ret	P	9,5	2	1,434	32,00	30	43,02	960	120*80*75
*60*119,5 (24"*47½") Bocciardato Ret - Level Ret	P	9,5	2	1,434	31,00	30	43,02	930	120*80*75
80*80 (31½"*31½") Nat/Ret - Lev/Ret	P	9,5	2	1,280	27,50	50	64	1375	120*80*96
*60*60 (24"*24") Nat/Ret	P	9,5	3	1,080	21,50	40	43,20	860	120*80*75
*60*60 (24"*24") Lev/Ret	P	9,5	3	1,080	22,50	40	43,20	900	120*80*75
*30*60 (12"*24") Nat/Ret	P	9,5	6	1,080	21,50	48	51,84	1032	120*80*75
*30*60 (12"*24") Lev/Ret	P	9,5	6	1,080	22,50	48	51,84	1080	120*80*75
*30*60 (12"*24") Maya Ret	P	9,5	6	1,080	21,50	40	43,20	860	120*80*75
*30*60 (12"*24") Weave Nat/Ret	P	9,5	6	1,080	21,50	40	43,20	860	120*80*75
*10*53 (4"*20") Chevron Nat/Ret	P	9,5	12	0,636	13,20	60	38,16	792	120*80*75
*30*30 (12"*12") Mosaico Nat/Ret	P	9,5	5	0,450	8,50	60	-	-	-
*30*30 (12"*12") Mosaico All In Ret	P	9,5	6	0,540	10,20	54	-	-	-
Pezzi Speciali / Special Pieces									
33*119,5 (13"*47½") Gradino Costa Retta Nat/Ret	P	9,5	2	0,789	18,50	20	-	-	-
8*60 (3¼"*24") Battiscopa Nat/Ret	P	9,5	10	0,480	11,00	72	-	-	-
8*60 (3¼"*24") Battiscopa Lev/Ret	P	9,5	10	0,480	11,00	72	-	-	-
8*80 (3½"*31½") Battiscopa Nat/Ret	P	10,5	7	0,450	11,00	65	-	-	-
8*80 (3½"*31½") Battiscopa Lev/Ret	P	10,5	7	0,450	11,00	65	-	-	-
6,5*120 (2½"*48") Battiscopa Nat/Ret - Lev/Ret	P	10,5	8	0,624	14,00	48	-	-	-

Special pieces
Formstücke
Pièces spéciales

Battiscopa Nat/Ret 8*60 – 3¼"*24" ± 9,5
Battiscopa Lev/Ret 8*60 – 3¼"*24" ± 9,5

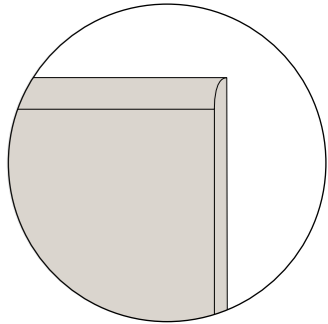
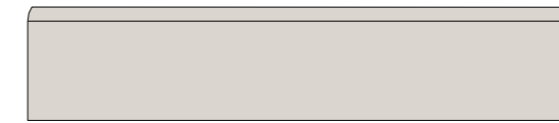

Battiscopa Nat/Ret 8*80 – 3½"*31½" ± 10,5
Battiscopa Lev/Ret 8*80 – 3½"*31½" ± 10,5

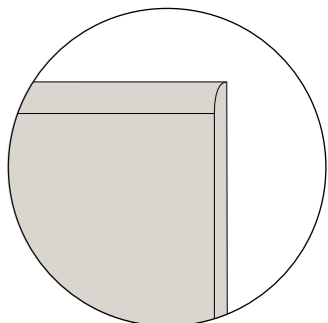
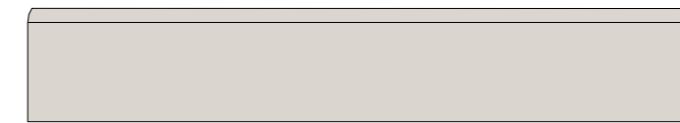

Battiscopa Nat/Ret 6,5*120 – 2½"*48" ± 10,5
Battiscopa Lev/Ret 6,5*120 – 2½"*48" ± 10,5

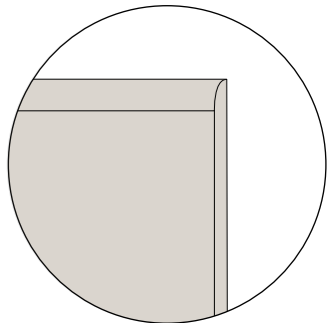
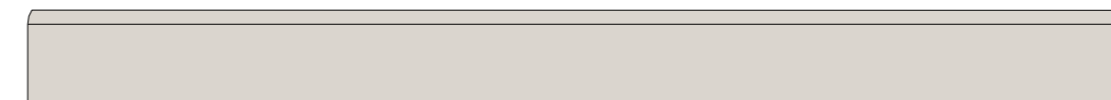

Gradino Costa Retta Nat/Ret 33*119,5 – 13"*47½" ± 9,5
(costa retta ottenuto per taglio e incollaggio - obtained by cutting and gluing)

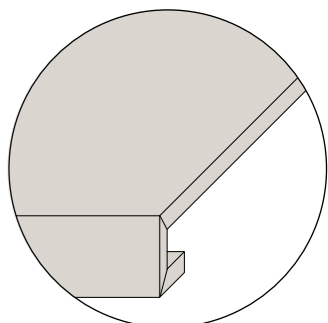
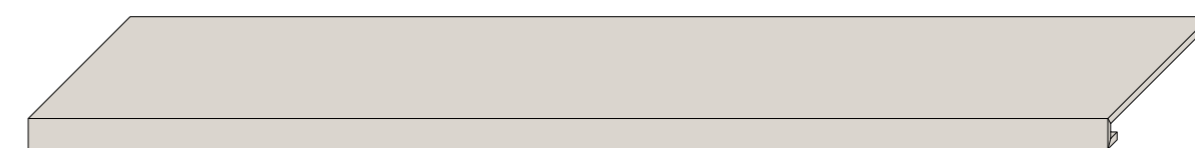

Caratteristiche Tecniche

Technical characteristics
Technische daten
Caracteristiques techniques

CLASSIFICAZIONE SECONDO NORME EN 14411 BJ_A – ISO 13006 – CLASSIFICATION IN ACCORDANCE WITH EN 14411 BJ_A – ISO 13006
KLASSIFIZIERUNG GEMÄSS NORMEN EN 14411 BJ_A – ISO 13006 – CLASSIFICATION SELON LES NORMES EN 14411 BJ_A – ISO 13006

CARATTERISTICA TECNICA TECHNICAL CHARACTERISTIC TECHNISCHE DATE CARACTÉRISTIQUE TECHNIQUE	NORMA NORM NORME	VALORE PRESCRITTO VALUE REQUIRED NORMVORGABE VALEUR PRESCRIPTE	VALORE MEDIO MEAN VALUE MITTELWERT VALEUR MOYENNE CERAMICHEPIEMME FLOOR AND MORE	NORMA NORM NORME	VALORE MEDIO MEAN VALUE MITTELWERT VALEUR MOYENNE CERAMICHEPIEMME FLOOR AND MORE
LUNGHEZZA E LARGHEZZA LENGHT AND WIDTH / LÄNGE UND BREITE / LONGUEUR ET LARGEUR		±0,6% (±2,00 MM)			
SPESORE THICKNESS / STÄRKE / EPAISSEUR		±5% (±0,5 MM)			
RETILINEITÀ LATI WARPAGES OF EDGES / GERADHEIT DER KANTEN / RÉCTITUDE DES ARÊTES	ISO 10545.2	±0,5% (±15 MM)	CONFORME IN ACCORDANCE ERFÜLLT CONFORME	ASTM C-499 ASTM C-485 ASTM C-502	IN ACCORDANCE
ORTOGONALITÀ WEDGING / RECHTWINKLIGKEIT / ORTHOGONALITÉ		±0,5% (±2,00 MM)			
PLANARITÀ FLATNESS / PLANITÄT / PLANIMÉTRIE		±0,5% (±2,00 MM)			
ASSORBIMENTO % D'ACQUA WATER ABSORPTION WASSERANNAHME % ABSORPTION D'EAU %	ISO 10545.3	≤ 0,5%	CONFORME IN ACCORDANCE ERFÜLLT CONFORME	ASTM C-373	IN ACCORDANCE
RESISTENZA ALLA FLESSIONE BENDING STRENGTH BIEGEZUGFESTIGKEIT RÉSISTANCE À LA FLEXION	ISO 10545.4	Modulus of rupture (average): R ≥ 35N/mm ² Breaking strength for thickness ≥ 7,5 mm S > 1500 N	CONFORME IN ACCORDANCE ERFÜLLT CONFORME	ASTM C-648 250 LBS OR GREATER	IN ACCORDANCE
DILATAZIONE TERMICA LINEARE TRA 20° E 100° C LINEAR THERMAL EXPANSION BETWEEN 20° AND 100° C LINEARE WÄRMEAUDEHNUNG ZWISCHEN 20° UND 100° C DILATATION THERMIQUE LINEAIRE ENTRE 20° ET 100° C	ISO 10545.8	SECONDO I DATI DEL COSTRUTTORE ACCORDING TO BUILDER'S SPECIFICATIONS LAUT ANGABEN DES HERSTELLERS SELON LES ELEMENTS DU CONSTRUCTEUR	≈ 7x10 ⁻⁶ C ⁻¹		
RESISTENZA AGLI SBALZI TERMICI THERMAL SHOCK RESISTANCE TEMPERATURWECHSELBESTÄNDIGKEIT RÉSISTANCE AUX ÉCARTS DE TEMPÉRATURE	ISO 10545.9	RICHIESTA REQUEST BITTE DEMANDE	RESISTENTE RESISTANT WIDERSTEHEND RÉSISTANT		
RESISTENZA AL GELO FROST RESISTANCE FROSTBESTÄNDIGKEIT RÉSISTANCE AU GEL	ISO 10545.12	RICHIESTA REQUEST BITTE DEMANDE	RESISTENTE RESISTANT WIDERSTEHEND RÉSISTANT	ASTM C-1026	IN ACCORDANCE
RESISTENZA ALL'ATTACCO CHIMICO RESISTANCE TO CHEMICAL ATTACK BESTÄNDIGKEIT GEGEN CHEMIKALIEN RÉSISTANCE À L'ATTAQUE CHIMIQUE	ISO 10545.13	SECONDO I DATI DEL COSTRUTTORE ACCORDING TO BUILDER'S SPECIFICATIONS LAUT ANGABEN DES HERSTELLERS SELON LES ELEMENTS DU CONSTRUCTEUR	RESISTENTE RESISTANT WIDERSTEHEND RÉSISTANT	ASTM C-650	IN ACCORDANCE
RESISTENZA DEI COLORI ALLA LUCE COLOURS RESISTANCE TO LIGHT LICHTBESTÄNDIGKEIT RÉSISTANCE DES COULEURS À LA LUMIÈRE	DIN 51094	NESSUNA ALTERAZIONE NO ALTERATION KEINE VERÄNDERUNG AUCUNE ALTERATION	CONFORME IN ACCORDANCE ERFÜLLT CONFORME		
RESISTENZA ALLE MACCHIE STAIN RESISTANCE FLECKENFESTIGKEIT RÉSISTANCE AUX TACHES	ISO 10545.14	≥ CLASSE 3 METODO DI PROVA DISPONIBILE TEST METHOD AVAILABLE VERFÜGBARE PRÜFMETHODE METHODE D'ESSAI DISPONIBLE	CONFORME IN ACCORDANCE ERFÜLLT CONFORME		
RESISTENZA ALLO SCIVOLAMENTO SLIPPAGE RESISTANCE RUTSCHSICHERHEIT RÉSISTANCE AU GLISSEMENT	DIN 51130 *	9 s R s13	NATURALE R10 LEVIGATO R11 ANTISLIP R11	ASTM C-1028 * COF ≥ 0,6 DRY ≥ 0,6 WET	NATURALE LEVIGATO ANTISLIP
	DIN 51097 *	A,B,C	NATURALE A+B LEVIGATO A+B+C ANTISLIP A+B+C	ANSI * 137,1-2012 DCOF > 0,42 WET	NATURALE > 0,42 LEVIGATO ANTISLIP > 0,42
	BS EN 7976-2*	> 36 DRY > 36 WET	NATURALE LEVIGATO ANTISLIP	AS 4586: 2013 CLASS	NATURALE LEVIGATO ANTISLIP

*TRATTANDOSI DI NORMATIVE NAZIONALI, I METODI DI PROVA, I REQUISITI E LE CLASSIFICAZIONI VARIANO DA PAESE A PAESE. IL VALORE ATTESO DALLA RESISTENZA ALLO SCIVOLAMENTO DELLA PRODUZIONE DI INDUSTRIE CERAMICHE PIEMME S.P.A., PUÒ VARIARE IN BASE AL LOTTO PRODUTTIVO. SPECIFICA DOCUMENTAZIONE È DISPONIBILE SU RICHIESTA. ELENCO DELLE SERIE CERTIFICATE E CLASSIFICAZIONI DISPONIBILI A RICHIESTA. TEST METHODS, REQUIREMENTS AND CLASSIFICATIONS DIFFER FROM COUNTRY TO COUNTRY, ACCORDING TO THE NATIONAL REGULATIONS. THE EXPECTED VALUE OF SLIPPAGE RESISTANCE OF PRODUCTS BY INDUSTRIE CERAMICHE PIEMME S.P.A. MAY VARY DEPENDING ON THE PRODUCTION BATCH. SPECIFIC DOCUMENTS ARE AVAILABLE UPON REQUEST. LIST OF CERTIFIED SERIES AND CLASSIFICATIONS AVAILABLE UPON REQUEST. PRÜFVERFAHREN, ERFORDERNISSE UND KLASSIFIKATIONEN SIND VERSCHIEDEN VON LAND ZU LAND, GEMÄSS DER NATIONALEN VORSCHRIFTEN. DER ERWARTUNGSWERT DER RUTSCHSICHERHEIT DER PRODUKTE VON INDUSTRIE CERAMICHE PIEMME S.P.A. KANN SICH - JE NACH DER PRODUKTIONSPARTIE - VERÄNDERN. SPEZIFISCHE UNTERLAGEN SIND AUF VERLANGEN ZUR VERFÜGUNG. LISTE DER GEPRÜFTEN SERIE UND KLASSIFIZIERUNGEN AUF ANFRAGE ERHÄLTICH. LES MÉTHODES D'ESSAI, LES RÉQUISITIONS ET LES CLASSIFICATIONS CHANGENT DE PAYS À PAYS, SELON LES RÉGLEMENTATIONS NATIONALES. LA VALEUR ATTENDUE DE RÉSISTANCE AU GLISSEMENT DES PRODUITS DE INDUSTRIE CERAMICHE PIEMME S.P.A. PEUT VARIER EN FONCTION DU LOT DE PRODUCTION. UNE DOCUMENTATION SPÉCIFIQUE EST DISPONIBLE SUR DEMANDE. LISTE DES SERIES CERTIFIÉES ET DES CLASSEMENTS DISPONIBLES SUR DEMANDE. CONCERNANT LA NORME UPEC, VEUILLEZ SVP VÉRIFIER DIRECTEMENT SUR INTERNET EN TAPANT "UPEC PIEMME" LES RÉFÉRENCES ET/OU FINITIONS ÉVENTUELLEMENT PAS ENCORE À CE JOUR CERTIFIÉES.



CERAMICHEPIEMME
FLOOR AND MORE



Norme per la posa e la manutenzione

Installation and maintenance instructions
Verlegung, reiningung und pflege
Guide a la pose et l'entretien

• Per i prodotti rettificati consigliamo una fuga di 2 mm per un migliore risultato di posa.

• Per una migliore resa estetica Piemme consiglia stuccature colorate in tinta con le piastrelle. Verificare, prima dell'utilizzo, la compatibilità ed idoneità dei riempitivi per fughe con il prodotto ceramico.

• Rimuovere le eccedenze dei riempitivi per fughe quando gli stessi sono ancora freschi.

• Attenersi scrupolosamente alle istruzioni indicate dai produttori dei riempitivi per fughe.

• Per eliminare completamente i residui di posa, che potrebbero compromettere la manutenzione ordinaria e le caratteristiche del prodotto, a posa ultimata, procedere con la pulizia utilizzando prodotti adeguati, a base Acida max 3%, rispettando le indicazioni del produttore. Osservare assolutamente i limiti di tempo indicati nelle istruzioni: un contatto troppo prolungato con questi prodotti potrebbe provocare il danneggiamento della superficie.

• Gli eventuali aloni che si dovessero presentare dopo la posa di materiali lappati o levigati si potranno facilmente eliminare utilizzando un prodotto idoneo, a base Alcalina.

• Riguardo l'utilizzo di materiali ceramici all'esterno, pure riconfermando l'ingelività dei prodotti Piemme in gres porcellanato, in conformità alle vigenti normative europee EN 14411/ISO 13006-ISO 10545.12, occorre attenersi ad alcune fondamentali norme previste per la posa all'esterno, atte a rendere inattaccabili al gelo i predetti pavimenti. Le condizioni più importanti da rispettare sono: le opportune pendenze, le impermeabilizzazioni, i giunti di dilatazione, e l'uso di idonei materiali per la posa.

• Decorazioni realizzate con smalti e metalli preziosi è indispensabile proteggere la superficie durante la posa, non utilizzare assolutamente prodotti abrasivi e/o acidi, ma solo acqua e sapone neutro. Il produttore non risponde di eventuali danni a questi preziosi materiali causati da "sfregamenti" durante la posa in opera. Per nessun motivo saranno accettate contestazioni relative a materiale posato.

• For better installation results of rectified products, we suggest 2 mm joint.

• For a better aesthetic finish, Piemme recommends using jointing colours that match the tiles.

• Please check, before using, the compatibility and suitability of grouting material with the ceramic tile.

• Clean away the excess of grouting materials while they are still fresh.

• Follow carefully the instructions pointed out by the producers of tile grouting materials.

• To completely eliminate installation residues, which could negatively affect routine maintenance and product characteristics once installation has terminated, proceed to clean using adequate products, with max. 3% Acid base, following the manufacturer's instructions. Always closely abide by the time limits indicated in the instructions: prolonged contact with these products may cause damage to the surface.

• Any rims that appear after installing lapped or polished materials can be easily eliminated using a suitable Alkaline-based product.

• With regard to the use of ceramic materials outdoors, while once more reiterating that Piemme porcelain stoneware products are frost-proof, in compliance with applicable European standards EN 14411/ISO 13006-ISO 10545.12, a number of fundamental procedures must be followed for outdoor installation, suitable for making the aforementioned floors resistant to frost. The most important aspects are: suitable gradients, waterproofing, expansion joints, and the use of suitable installation materials.

• Decorations made with glazes and precious metals It is most important to protect the surface during installation. Never use abrasive and/or acid products, only water and neutral soap. The manufacturer disclaims liability in case of any damage to these precious materials caused by "rubbing" during installation. Under no circumstances will disputes be accepted relating to the installed material.

• Damit sich eine bessere Verlegung von geschliffenen Produkten ergibt, empfehlen wir eine Fugenbreite von 2 mm. Für ein optisch perfektes Ergebnis empfiehlt Piemme, die Fugen farblich auf die Fliesen abzustimmen.

• Prüfen sie bitte, vor der Verwendung, die Zweckmäßigkeit und die Verträglichkeit des Fugenfüllmittels mit den Keramikfliesen.

• Bitte entfernen sie das überflüssige Fugenfüllmittel wenn es noch frisch ist.

• Folgen sie bitte sorgfältig die von dem Herstellern des Fugenfüllmittels angegebenen Bedienungsvorschriften.

• Zur vollkommenen Entfernung der Verlegerückstände, die die normale Pflege erschweren und die Merkmale des Produkts beeinträchtigen könnten, nach der Verlegung geeignete Reinigungsmittel auf max. 3% Säurebasis verwenden und bei der Reinigung die Hinweise des Herstellers beachten. Die angegebenen Zeiten keinesfalls überschreiten: ein zu lange andauernder Kontakt mit diesen Produkten kann Beschädigungen der Oberfläche verursachen.

• Eventuelle nach der Verlegung von geläpftem oder geschliffenem Material sichtbare Schleier lassen sich einfach mit entsprechenden, alkalischen Produkten entfernen.

• Auch wenn die Piemme-Feinsteinzeugprodukte gemäß den europäischen Normen EN 14411/ISO 13006-ISO 10545.12 frostbeständig sind, müssen beim Einsatz keramischer Materialien im Freien einige Grundregeln beachtet werden, damit die Bodenbeläge nicht vom Frost angegriffen werden können. Die wichtigsten Voraussetzungen sind: korrektes Gefälle, Abdichtung, Dehnungsfugen sowie geeignetes Verlegematerial.

• Dekore mit Glasuren und Edelmetallen Während der Verlegung muss die Oberfläche unbedingt abgedeckt werden. Es dürfen keine scheuernden und/oder säurehaltigen Produkte verwendet werden, sondern ausschließlich Wasser und neutrale Seife. Der Hersteller haftet nicht für eventuelle, während der Verlegung durch Abrieb entstandene Schäden an diesen hochwertigen Materialien. Reklamationen von bereits verlegtem Material werden in keinem Fall akzeptiert.

• Pour obtenir le meilleur résultat de pose de produits rectifiés, il est conseillé de réaliser un joint de 2 mm.

• Pour parfaire l'effet esthétique obtenu, Piemme conseille de confectionner des joints de la même couleur que les carreaux.

• Vérifier avant la pose la compatibilité et convenance des remplissages pour joints avec le produit céramique.

• Enlever les surplus des remplissages pour joints alors qu'ils sont encore frais.

• Respecter scrupuleusement les instructions indiquées par les fabricants de remplissages pour joints.

• Pour éliminer complètement tout résidu de pose pouvant gêner l'entretien courant et altérer les caractéristiques du produit, il est conseillé, à la fin de la pose, de procéder au nettoyage du carrelage avec des produits à base acide maximum 3% et de respecter les consignes du fabricant. Suivre impérativement les délais indiqués dans la notice car le contact trop prolongé de ces produits pourrait endommager la surface.

• Pour éliminer facilement la présence éventuelle de cernes après la pose de carreaux rodés ou polis, utiliser un produit à base alcaline.

• Pour ce qui est de la pose à l'extérieur, bien que les produits Piemme en grès cérame soient ingélifs, conformément aux normes européennes EN 14411/ISO 13006-ISO 10545.12, il convient cependant de respecter quelques règles fondamentales de manière à rendre le carrelage inattaquable au gel. Les conditions les plus importantes à remplir sont: le degré d'inclinaison, l'imperméabilisation, les joints de dilatation et l'utilisation de matériaux de pose appropriés.

• Décorés réalisés avec des émaux et des métaux précieux Il est indispensable de protéger la surface pendant la pose. N'utiliser en aucun cas des produits abrasifs et/ou acides mais uniquement de l'eau et du savon neutre. Le fabricant ne répond pas des dommages éventuels de ces matériaux précieux causés par le frottement pendant la pose. Aucune réclamation, quelle qu'elle soit, concernant le matériau posé ne sera acceptée.

TIPO DI SPORCO	INDICAZIONI PER LA PULIZIA
Birra, Caffè, Gelato, Vino Gomma Pneumatico, Grassi vegetali e animali, Inchiostri, Lampostili Oili Meccanici, Residui di scotch Ollo di lino, PennarelloResine Smalti, Tintura per capelli	Prodotti a Base Alcalina
Cera protettiva anti-abrasione, Depositi calcarei, Macchie di ruggine	Prodotti a Base Acida
Cera di candela, Residui di scotch	Solventi
Per ulteriori informazioni specifiche consultare l'area tecnica sul sito Piemme: www.ceramichepiemme.it	

TYPE OF STAIN	CLEANING SUGGESTIONS
beer, coffee, wine, ice cream vegetable and animal fats, rubber, remains of scotch tape, grease from machines, linseed oil, felt tip pens, paints, inks, hair dye	Alkaline-based detergent
protective anti-abrasion wax, calcareous residuals, rust stains	Acid-based detergent
candle wax, remains of scotch-tape	Solvents

For further specific details please visit the technical area on Piemme website: www.ceramichepiemme.it

VERSCHMUTZUNGSART	REINIGUNGSHINWEISE
Bier, Wein, Eis, Kaffee Tierische oder pflanzliche Fette Gummi, Kleberbandresten Schmieröl, Tinte, Leilöl, Filzstift, Harz oder Lack, Haarfarbe	Alkalische Reinigungsmittel
Kratzschutz-Wachs, Kalkablagerunge, Rostflecken	Säure-Reinigungsmittel
Kerzenwachs Kleberbandresten	Lösungsmittel
Weitere Einzelheiten finden Sie in dem technischen Bereich des Piemme website: www.ceramichepiemme.it	

TYPE DE TACHE	NETTOYAGE CONSEIL
Bière, Vin, Glace, Café, Graisses végétales et animales, Encres, Résidus de scotch, Huile de graisseage, Hile de lin Crayon feutre Emaux, Teinture pour cheveux, Caoutchouc pour pneus	Détergents à base alcaline
Cire de protection anti abrasion, Dépôts de calcaire, Tache de rouille	Détergents à base d'acide
Cire de bougie Résidus de scotch	Solvant

Pour d'ultérieures Information spécifiques consulter le département technique du site Piemme: www.ceramichepiemme.it

Reading Guide
Leseanleitung
Guide à la lecture

▼ Spessore
Thickness
Stärke
Épaisseur

Variazione nelle sfumature di colore
Color shade variations
Variation der Farbnuancen
Variation des nuances de couleur

Resistenza alla scivolosità
Skid resistance
Rutschfestigkeit
Resistance au glissement

V1 Aspetto uniforme
Uniform appearance
Gleichförmiges aussehen
Aspect uniforme

V2 Variazione leggera
Slight variation
Leichte variation
Variation légère

V3 Variazione moderata
Moderate variation
Mäßige variation
Variation modeste

V4 Variazione casuale
Random variation
Zufällige variation
Variation fortuite

DIN 51130	DIN 51097	DCOF
R10	A	>0,42

Tutti i formati sono nominali.

Gli spessori riportati in questo catalogo sono nominali e possono variare a seconda dei formati e delle finiture.

I colori e le caratteristiche estetiche dei prodotti sono quanto più possibile vicini a quelli reali, nei limiti consentiti dai processi di stampa.

All sizes are nominal.

The thickness mentioned on this catalogue are nominal and can be different according to the sizes and the finishes.

The colours and appearance features of the products are as close as possible to reality, within the limitation of the printing process.

Die Formate sind Nennwerte.

Die in diesem Katalog angegebenen Fliesenstärke sind nominal und können, je nach Format oder Oberfläche, verschieden sein.

Die Farben und die ästhetischen Eigenschaften der Produkte entsprechen der Wirklichkeit, innerhalb den von dem Druckverfahren erlaubten Grenzen.

Tous les formats sont nominaux.

Les épaisseurs reportées sur ce catalogue sont nominales et peuvent varier suivant les formats et les finitions.

Les couleurs et les caractéristiques esthétiques sont fidèles aux couleurs et caractéristiques réelles dans les limites des procédés d'impression.



Ceramics of Italy rappresenta la volontà dell'industria italiana delle piastrelle di ceramica nel diffondere e promuovere una nuova valenza della piastrella di ceramica: non più solo un prodotto per l'industria delle costruzioni, ma punto di riferimento per stile e creatività per lo sviluppo di una nuova cultura dell'abitare Made in Italy.

Ceramics of Italy represents the willingness of the Italian ceramic tile industry to spread and promote a new concept of ceramic tile: no longer just a product for the construction industry, but a focal point for style and creativity in the development of a new culture of living Made in Italy.

Project Management
Mktg Piemme

Febbraio 2022
February 2022

Una storia tutta italiana

Piemme dal 1962, anno della sua fondazione, è protagonista indiscussa del vero Made in Italy, quello fatto di eccellenza, passione e creatività. Oggi tutti i materiali Piemme sono prodotti con tecnologia d'avanguardia come la decorazione digitale inkjet HD, la cottura in forni ad energia pulita a recupero di calore, la rettifica e levigatura in linea "one roof" e la verifica elettronica dello standard qualitativo.

An all-Italian story

Since 1962, the year of its foundation, Piemme has been the undisputed protagonist of real Made in Italy, that which consists of excellence, passion and creativity. Today, all Piemme materials are made using cuttingedge technology such as HD inkjet digital decoration, firing in heat-recycling cleanenergy kilns, "one roof" grinding and polishing line and electronic quality standard control.

Eine ganz italienische Geschichte

Seit dem Gründungsjahr 1962 ist Piemme ein unangefochtener Hauptakteur des echten Made in Italy: jenem, das auf Exzellenz, Leidenschaft und Kreativität gründet. Alle Piemme Erzeugnisse werden heute unter Einsatz von Spitzentechnologie produziert, wie zum Beispiel mit der digitalen Inkjet-Dekoration, dem Brennen in Öfen mit grüner Energie und Wärmerückgewinnung, dem Schleifen und Polieren in der Linie „unter einem Dach“ sowie der elektronischen Prüfung des Qualitätsniveaus.

Une histoire toute italienne

Depuis 1962, l'année de sa fondation, Piemme est la protagoniste indiscutée du Made in Italy, basé sur l'excellence, la passion et la créativité. Aujourd'hui toutes les phases du cycle de fabrication Piemme sont issues d'une technologie à l'avant-garde comme la décoration numérique inkjet HD, la cuisson dans des fours à énergie propre et à récupération de chaleur, la rectification et le polissage en en ligne "one roof" et la vérification électronique de la qualité.

CERAMICHE PIEMME

FLOOR AND MORE

INDUSTRIE CERAMICHE PIEMME S.P.A.
VIA DEL CROCIALE 42/44, 41042 FIORANO (MO) - ITALY
T. +39 0536.849111 - F. +39 0536.849402
WWW.CERAMICHEPIEMME.IT - INFO@CERAMICHEPIEMME.IT